

6677/01

Edexcel GCE

Mechanics M1

Gold Level G4

Time: 1 hour 30 minutes

Materials required for examination

Mathematical Formulae (Pink)

Items included with question papers

Nil

Candidates may use any calculator allowed by the regulations of the Joint Council for Qualifications. Calculators must not have the facility for symbolic algebra manipulation, differentiation and integration, or have retrievable mathematical formulas stored in them.

Instructions to Candidates

In the boxes on the answer book, write the name of the examining body (Edexcel), your centre number, candidate number, the unit title (Mechanics M1), the paper reference (6677), your surname, other name and signature.

Whenever a numerical value of g is required, take $g = 9.8 \text{ m s}^{-2}$.

When a calculator is used, the answer should be given to an appropriate degree of accuracy.

Information for Candidates

A booklet 'Mathematical Formulae and Statistical Tables' is provided.

Full marks may be obtained for answers to ALL questions.

There are 8 questions in this question paper. The total mark for this paper is 75.

Advice to Candidates

You must ensure that your answers to parts of questions are clearly labelled.

You must show sufficient working to make your methods clear to the Examiner. Answers without working may gain no credit.

Suggested grade boundaries for this paper:

A*	A	B	C	D	E
56	49	42	35	27	20

1. Three posts P , Q and R , are fixed in that order at the side of a straight horizontal road. The distance from P to Q is 45 m and the distance from Q to R is 120 m. A car is moving along the road with constant acceleration $a \text{ m s}^{-2}$. The speed of the car, as it passes P , is $u \text{ m s}^{-1}$. The car passes Q two seconds after passing P , and the car passes R four seconds after passing Q .

Find

- (i) the value of u ,
(ii) the value of a .

(7)

2. A woman travels in a lift. The mass of the woman is 50 kg and the mass of the lift is 950 kg. The lift is being raised vertically by a vertical cable which is attached to the top of the lift. The lift is moving upwards and has constant deceleration of 2 m s^{-2} . By modelling the cable as being light and inextensible, find

- (a) the tension in the cable,

(3)

- (b) the magnitude of the force exerted on the woman by the floor of the lift.

(3)

3. A particle is acted upon by two forces \mathbf{F}_1 and \mathbf{F}_2 , given by

$$\mathbf{F}_1 = (\mathbf{i} - 3\mathbf{j}) \text{ N},$$

$$\mathbf{F}_2 = (p\mathbf{i} + 2p\mathbf{j}) \text{ N}, \text{ where } p \text{ is a positive constant.}$$

- (a) Find the angle between \mathbf{F}_2 and \mathbf{j} .

(2)

The resultant of \mathbf{F}_1 and \mathbf{F}_2 is \mathbf{R} . Given that \mathbf{R} is parallel to \mathbf{i} ,

- (b) find the value of p .

(4)

4. Two particles A and B are moving on a smooth horizontal plane. The mass of A is $2m$ and the mass of B is m . The particles are moving along the same straight line but in opposite directions and they collide directly. Immediately before they collide the speed of A is $2u$ and the speed of B is $3u$. The magnitude of the impulse received by each particle in the collision is $\frac{7mu}{2}$.

Find

- (a) the speed of A immediately after the collision, (3)
- (b) the speed of B immediately after the collision. (3)
-

5. **Figure 1**

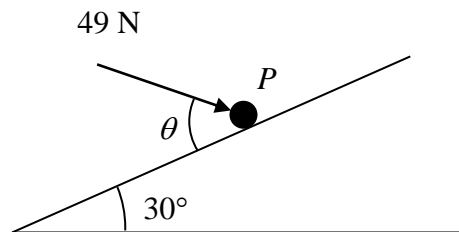

A particle P of mass 6 kg lies on the surface of a smooth plane. The plane is inclined at an angle of 30° to the horizontal. The particle is held in equilibrium by a force of magnitude 49 N , acting at an angle θ to the plane, as shown in Figure 1. The force acts in a vertical plane through a line of greatest slope of the plane.

- (a) Show that $\cos \theta = \frac{3}{5}$. (3)
- (b) Find the normal reaction between P and the plane. (4)

The direction of the force of magnitude 49 N is now changed. It is now applied horizontally to P so that P moves up the plane. The force again acts in a vertical plane through a line of greatest slope of the plane.

- (c) Find the initial acceleration of P . (4)
-

6.

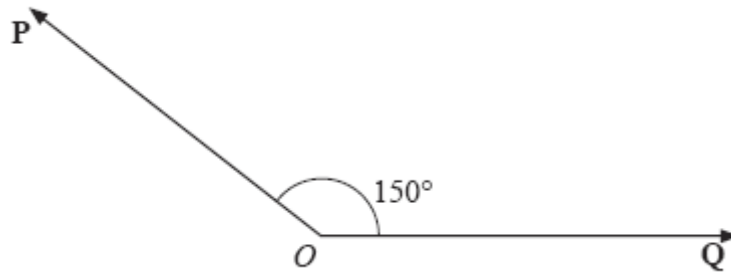

Figure 1

Two forces \mathbf{P} and \mathbf{Q} act on a particle at a point O . The force \mathbf{P} has magnitude 15 N and the force \mathbf{Q} has magnitude X newtons. The angle between \mathbf{P} and \mathbf{Q} is 150° , as shown in Figure 1. The resultant of \mathbf{P} and \mathbf{Q} is \mathbf{R} .

Given that the angle between \mathbf{R} and \mathbf{Q} is 50° , find

(a) the magnitude of \mathbf{R} , (4)

(b) the value of X . (5)

7. Two forces, $(4\mathbf{i} - 5\mathbf{j})$ N and $(p\mathbf{i} + q\mathbf{j})$ N, act on a particle P of mass m kg. The resultant of the two forces is \mathbf{R} . Given that \mathbf{R} acts in a direction which is parallel to the vector $(\mathbf{i} - 2\mathbf{j})$,

(a) find the angle between \mathbf{R} and the vector \mathbf{j} , (3)

(b) show that $2p + q + 3 = 0$. (4)

Given also that $q = 1$ and that P moves with an acceleration of magnitude $8\sqrt{5} \text{ m s}^{-2}$,

(c) find the value of m . (7)

8.

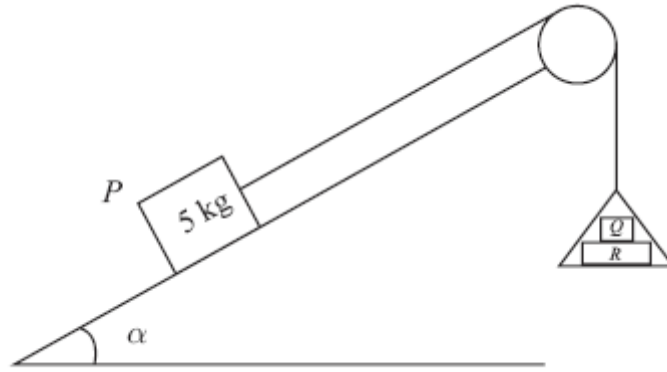

Figure 3

One end of a light inextensible string is attached to a block P of mass 5 kg. The block P is held at rest on a smooth fixed plane which is inclined to the horizontal at an angle α , where $\sin \alpha = \frac{3}{5}$. The string lies along a line of greatest slope of the plane and passes over a smooth light pulley which is fixed at the top of the plane. The other end of the string is attached to a light scale pan which carries two blocks Q and R , with block Q on top of block R , as shown in Figure 3. The mass of block Q is 5 kg and the mass of block R is 10 kg. The scale pan hangs at rest and the system is released from rest. By modelling the blocks as particles, ignoring air resistance and assuming the motion is uninterrupted, find

(a) (i) the acceleration of the scale pan,

(ii) the tension in the string,

(8)

(b) the magnitude of the force exerted on block Q by block R ,

(3)

(c) the magnitude of the force exerted on the pulley by the string.

(5)

TOTAL FOR PAPER: 75 MARKS

END

Question Number	Scheme	Marks
1.	$45 = 2u + \frac{1}{2}a2^2 \Rightarrow 45 = 2u + 2a$ $165 = 6u + \frac{1}{2}a6^2 \Rightarrow 165 = 6u + 18a$ <p>eliminating either u or a</p> $u = 20 \text{ and } a = 2.5$	M1 A1 M1 A1 M1 A1 A1 (7 marks)

2. (a)	For system, $(\uparrow), T - 950g - 50g = 1000 \times -2$ $T = 7800 \text{ N}$	M1 A1 A1 (3)
(b)	For woman, $(\uparrow), R - 50g = 50 \times -2$ $R = 390 \text{ N}$	M1 A1 A1 (3)
		[6]

3. (a)	$\tan \theta = \frac{p}{2p} \Rightarrow \theta = 26.6^\circ$	M1 A1 (2)
(b)	$\mathbf{R} = (\mathbf{i} - 3\mathbf{j}) + (p\mathbf{i} + 2p\mathbf{j}) = (1 + p)\mathbf{i} + (-3 + 2p)\mathbf{j}$ \mathbf{R} is parallel to $\mathbf{i} \Rightarrow (-3 + 2p) = 0$ $\Rightarrow p = \frac{3}{2}$	M1 A1 DM1 A1 (4) (6 marks)

4. (a)	For A: $-\frac{7mu}{2} = 2m(v_A - 2u)$ $v_A = \frac{u}{4}$	M1 A1 A1 (3)
(b)	For B: $\frac{7mu}{2} = m(v_B - -3u)$ $v_B = \frac{u}{2}$	M1 A1 A1 (3) (6 marks)

5 (a)	<p>R (// plane): $49 \cos \theta = 6g \sin 30$ $\Rightarrow \cos \theta = 3/5$ *</p>	M1 A1 A1 (3)
(b)	<p>R (perp to plane): $R = 6g \cos 30 + 49 \sin \theta$ $R \approx \underline{90.1 \text{ or } 90 \text{ N}}$</p>	M1 A1 DM1 A1 (4)
(c)	<p>R (// to plane): $49 \cos 30 - 6g \sin 30 = 6a$ $\Rightarrow a \approx 2.17 \text{ or } 2.2 \text{ m s}^{-2}$</p>	M1 A2,1,0 A1 (4)
		11

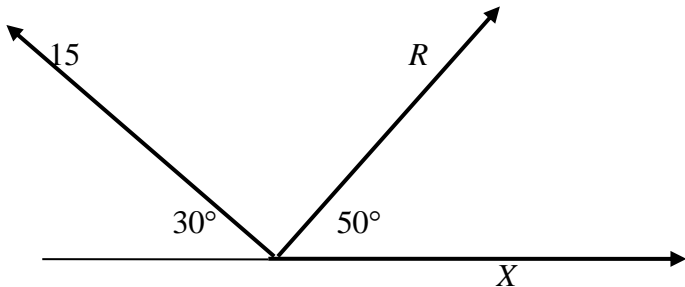
6.	(a)	 <p>(↑) $15 \sin 30^\circ = R \sin 50^\circ$ $R \approx 9.79 \text{ (N)}$</p> <p>(→) $X - 15 \cos 30^\circ = R \cos 50^\circ$ ft</p>	M1 A1 M1 A1 (4)
	(b)	<p>their R</p> <p>$X \approx 19.3 \text{ (N)}$</p>	M1 A2 ft M1 A1 (5) (9 marks)

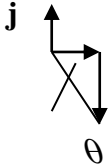
Question Number	Scheme	Marks
7 (a)	 $\tan \theta = \frac{2}{1} \Rightarrow \theta = 63.4^\circ$ <p>angle is 153.4°</p>	M1 A1 A1 (3)
(b)	$(4 + p)\mathbf{i} + (q - 5)\mathbf{j}$ $(q - 5) = -2(4 + p)$ $2p + q + 3 = 0 *$	B1 M1 A1 A1 (4)
(c)	$q = 1 \Rightarrow p = -2$ $\Rightarrow \mathbf{R} = 2\mathbf{i} - 4\mathbf{j}$ $\Rightarrow \mathbf{R} = \sqrt{2^2 + (-4)^2} = \sqrt{20}$ $\sqrt{20} = m8\sqrt{5}$ $\Rightarrow m = \frac{1}{4}$	B1 M1 M1 A1 f.t. M1 A1 f.t. A1 cao (7) [14]

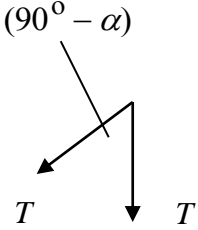
Question Number	Scheme	Marks
8 (a)	$T - 5g \sin \alpha = 5a$ $15g - T = 15a$ solving for a $a = 0.6g$ solving for T $T = 6g$	M1 A1 M1 A1 M1 A1 M1 A1 (8)
(b)	For Q : $5g - N = 5a$ $N = 2g$	M1 A1 A1 f.t. (3)
(c)	 $F = 2T \cos\left(\frac{90^\circ - \alpha}{2}\right)$ $= 12g \cos 26.56^\circ$ $= 105 \text{ N}$	M1 A2 A1 f.t. A1 (5) [16]

Examiner reports

Question 1

This was a more difficult question 1 than usual, in that neither u nor a could be found directly from the given information and it was necessary to set up a pair of simultaneous equations. Many were able to write down an equation for the motion from P to Q but then struggled to find another one. By far the most common error was to say that the average velocity over an interval was equal to the actual velocity at one end of it. Those candidates who produced two correct equations invariably produced the correct answers. A few candidates found the acceleration but then forgot to find the value of u .

Question 2

Part (a) was mostly well done with the vast majority attempting an equation of motion for the whole system. The most common error was the omission of the minus sign on the acceleration. The second part proved to be a discriminator and revealed a lack of understanding of the basic principles. A significant number treated it as a statics problem, even though they had used an acceleration in part (a), and tried assuming the forces were in equilibrium. Amongst those who did attempt to write down an equation of motion for the woman alone, there was much confusion over which forces were acting on her, with many including the tension in the lift cable.

Question 3

In part (a) the majority of candidates were able to find the correct angle. For those that didn't the most common error was to find the complementary angle. In the second part, provided that it was realised that the sum of the \mathbf{j} components was equal to zero, full marks were usually achieved. A significant number of candidates equated the sum of the \mathbf{i} components to zero.

Question 4

Impulses continue to cause problems and a correct solution to part (a) was rarely seen. Most candidates know that impulse = change in momentum but few can cope with the signs correctly and the impulse in the first part almost always had the wrong sign. The second part produced more success and if the impulse-momentum principle was used again, this part was independent of part (a) and so full marks could be scored. Some tried to use the conservation of momentum principle in part (b), but this relied on using their possibly incorrect answer to part (a).

Question 5

Throughout this question candidates' answers were marred by confusion between 30° / θ , \cos/\sin , and even horizontal/ parallel to the plane.

Part (a) caused a few problems and sometimes it was not attempted, even though parts (b) and (c) were fully correct. An exact fraction, using $g = 9.8$, was required so that recourse to inexact decimals lost marks. In part (b) a significant number of candidates lost the final mark by leaving their answer as 90.12. In the final part many candidates treated the 49 as a force up the slope, rather than horizontal, so failed to resolve up the slope thus failing to score any marks here.

Question 6

This question, involving a resultant force, was not well answered by many candidates, although there were also a fair number of full marks seen. There were two possible approaches (resolving and sine/cosine rule). Some treated it as an equilibrium problem and used correct terms in resolving but with sign errors. Some who used the triangle approach used a triangle with **R** (the resultant) opposite an angle of 150° rather than 30° . This enabled them to find the correct numerical value for the magnitude of **R** by the sine rule but then it was difficult to achieve any more marks since it was impossible to find a third angle. A number of candidates made no significant progress in answering this question; there was a lot of crossed out working seen.

Question 7

Many were able, in the first part, to use tan to find an acute angle, scoring two of the three marks, but were then unable to identify and find the required angle. In part (b), the first mark was for adding the two vectors together but many students then stated that this sum was equal to $(\mathbf{i} - 2\mathbf{j})$ rather than a multiple of it and were unable to make any progress. In the final part, many who failed in (b), obtained $p = -2$ from the printed equation and, even if their **R** was wrong, were able to benefit from follow-through marks. It was amazing to see so many arrive correctly at $\sqrt{20} = m8\sqrt{5}$ then correctly write $m = 2\sqrt{5} / 8\sqrt{5}$ but then give $m = 5/4$!

Question 8

In part (a), most candidates were able to set up the two equations of motion, one for each of the two particles and most then went on to solve these correctly to find values for both T and a . A few persist in trying to use a “whole system” equation to find a , usually with limited success. In the second part the vast majority of candidates were unable to select the correct particle, forces or equation to score any of the marks. Part (c) also proved to be discriminating, with some weaker candidates not attempting it. Only a minority of candidates managed to produce a correct solution. Of those who did, many used the cosine rule applied to a vector triangle, or a resolution into two perpendicular components. Common misconceptions involved using just $T + T \sin/\cos$ alpha or answers involving components of $5g$ and $15g$. Many had difficulty in identifying the correct size for the angle whichever method was attempted. A few very good candidates realised that the force acted along the angle bisector and scored five quick marks.

Statistics for M1 Practice Paper Gold Level G4

Original paper	Qu	Mean score	Max score	Mean %	Mean score for students achieving grade:						
					ALL	A	B	C	D	E	U
0906	1	3.72	7	53	3.72	5.51	3.79	2.94	2.25	1.74	1.03
1306	2	3.38	6	56	3.38	4.60	3.71	3.11	2.56	1.97	1.05
0906	3	3.23	6	54	3.23	4.78	3.35	2.58	1.95	1.59	0.76
0906	4	2.65	6	44	2.65	3.66	2.85	2.44	2.03	1.53	0.74
0801	5	6.26	11	57	6.26	8.71	6.65	5.04	3.58	2.00	0.88
0806	6	4.40	9	49	4.40	6.73	4.55	3.29	2.48	1.90	0.85
0901	7	5.51	14	39	5.51	9.08	4.46	3.05	2.20	1.57	0.64
0901	8	6.16	16	39	6.16	8.78	6.17	4.74	3.89	2.61	1.25
		35.31	75	47	35.31	51.85	35.53	27.19	20.94	14.91	7.20