

GCSE (9–1) Mathematics

J560/03 Paper 3 (Foundation Tier)

Tuesday 13 June 2017 – Morning

Time allowed: 1 hour 30 minutes



You may use:

- A scientific or graphical calculator
- Geometrical instruments
- Tracing paper



First name										
Last name										
Centre number						Candidate number				

INSTRUCTIONS

- Use black ink. You may use an HB pencil for graphs and diagrams.
- Complete the boxes above with your name, centre number and candidate number.
- Answer **all** the questions.
- Read each question carefully before you start to write your answer.
- Where appropriate, your answers should be supported with working. Marks may be given for a correct method even if the answer is incorrect.
- Write your answer to each question in the space provided.
- Additional paper may be used if required but you must clearly show your candidate number, centre number and question number(s).
- Do **not** write in the barcodes.

INFORMATION

- The total mark for this paper is **100**.
- The marks for each question are shown in brackets [].
- Use the π button on your calculator or take π to be 3.142 unless the question says otherwise.
- This document consists of **20** pages.

Answer **all** the questions.

1 (a) Complete this table of fractions, decimals and percentages.

Fraction		Decimal		Percentage
$\frac{1}{2}$	=	0.5	=	50%
	=	0.27	=	
$\frac{4}{5}$	=		=	
	=		=	3%

[3]

(b) Write 45% as a fraction in its simplest form.

(b) [2]

(c) Alan and Brian share a sum of money in the ratio 1 : 4.

What fraction of the money does Alan receive?

(c) [1]

2 Corinne invests £8400 at a simple interest rate of 12% per year.

Work out the value of the investment after 3 years.

£ [3]

- 3 (a) Find the value of y .

$$5 \times 5 \times 5 \times 5 \times 5 \times 5 \times 5 = 5^y$$

(a) $y = \dots\dots\dots$ [1]

- (b) Find the values of z .

$$z^2 = 196$$

(b) $z = \dots\dots\dots$ or $z = \dots\dots\dots$ [2]

- 4 (a) Expand and simplify.

$$5(x - 2) - 2(x - 4)$$

(a) $\dots\dots\dots$ [2]

- (b) Factorise fully.

$$10x^2 + 6x$$

(b) $\dots\dots\dots$ [2]

- (c) Simplify.

$$(x^5)^2$$

(c) $\dots\dots\dots$ [1]

5 (a) Find the value of $3a + 2b$ when $a = 16$ and $b = 7$.

(a) [2]

(b) Use the formula

$$v = u + at$$

to find the final velocity, when

- the initial velocity is 2 m/s
- the acceleration is 1.5 m/s^2
- the time is 6 seconds.

(b)m/s [2]

(c) Make d the subject of this formula.

$$c = 7d$$

(c) [1]

- 6 (a) Henry puts eight counters into a bag. Each counter has a different whole number on it between 1 and 8. He picks a counter at random from the bag and the number is noted.

Choose from the words in the box to complete each sentence.

likely impossible certain evens unlikely

- (i) It is that he picks a number less than 9. [1]
- (ii) It is that he picks an odd number. [1]

- (b) The Venn diagram shows the number of students who passed their examination in French (F) and those who passed their examination in Mathematics (M). The number of students who did not pass either examination is b .

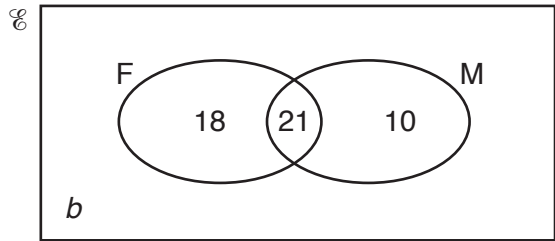

- (i) Find the value of b if the total number of students is 55.

(b)(i) $b =$ [1]

One of the 55 students is selected at random.

What is the probability that this student

- (ii) passed both French and Mathematics,

(ii) [1]

- (iii) passed exactly one of these two subjects?

(iii) [1]

6

- 7 Hardeep buys 11 identical shirts and 24 identical ties for £403.51.
The cost of a shirt is £15.65.

Find the cost of a tie.

£ [4]

- 8 (a) Harry needs dollars to go on holiday.
He can buy \$50 for £40.

How much will \$720 cost at the same rate?

(a) £..... [2]

- (b) Tony returns from holiday with these notes.

Note	Number of notes
€50	2
€20	4
€10	9
€5	12

The exchange rate is £1 = €1.17.

Work out how much he will get in total when he changes these notes.

(b) £..... [4]

9 (a) Round 7.3065 to 2 decimal places.

(a) [1]

(b) Round each number to 3 significant figures.

(i) 408231

(b)(i) [1]

(ii) 0.006 137 02

(ii) [1]

10 (a) Write down the second and third terms of the following two sequences.

(i) Rule : To get the next term **subtract 4** from the previous term.
First term = 19.

19 [1]

(ii) Rule : To get the next term **multiply** the previous term **by 5** and then **add 3**.
First term = 7.

7 [1]

(b) Here are the first four terms of another sequence.

5 9 13 17

Write an expression for the *n*th term of this sequence.

(b) [2]

- 11 (a) Grapes cost £2 per kilogram.

Calculate the cost of 380 g of grapes.

(a) £ [2]

- (b) Ruth buys 19 identical tickets for £280.25.

Estimate the cost of one ticket.
Show your working.

(b) £ [2]

- 12 The shape below is formed from a rectangle measuring 12 cm by 15 cm from which a rectangle of length 7.4 cm has been removed.

Not to scale

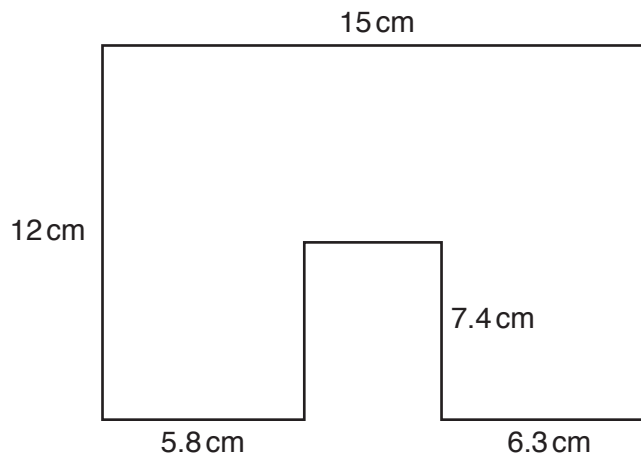

Work out the perimeter of the shape.

.....cm [3]

- 13 (a) The mass, m tonnes, of a girder is 12.7, correct to 1 decimal place.

Complete the error interval for the mass, m .

(a) $\leq m <$ [2]

- (b) The length of a piece of wood is given as 8 metres, correct to the nearest metre.
The length of a metal rod is given as 8.5 metres, correct to 1 decimal place.

Show that the piece of wood could be longer than the metal rod. [2]

14 Triangle **A** and triangle **B** are drawn on the coordinate grid.

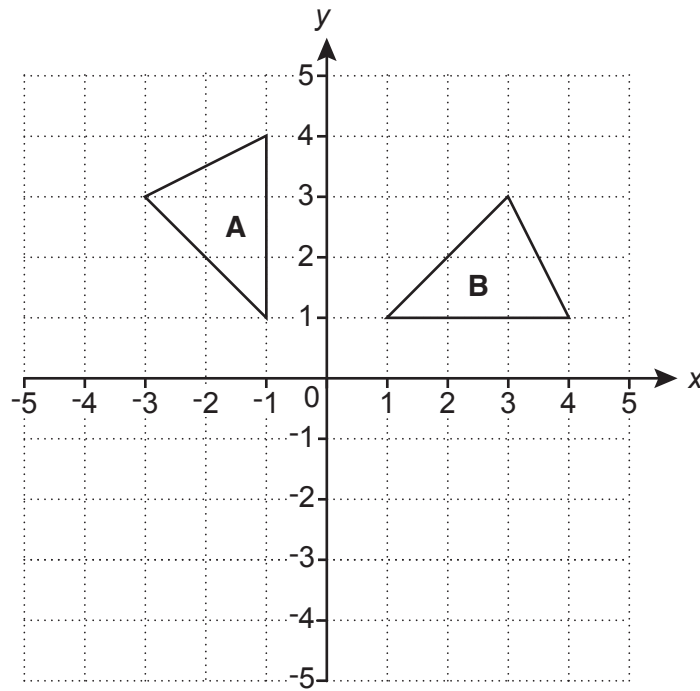

(a) Translate triangle **A** by vector $\begin{pmatrix} 3 \\ -5 \end{pmatrix}$. [2]

(b) Describe fully the **single** transformation that maps triangle **A** onto triangle **B**.

.....

..... [3]

- 15 Students at a school must choose one subject from Option 1 and one from Option 2. The school offers two languages, French and Spanish.

The subjects are given in this table.

Option 1	Option 2
French	Spanish
Art	Geography
Music	History
Economics	

Work out the percentage of all the subject combinations which have exactly one language.

..... % **[4]**

- 16 (a) The owner of a tourist attraction records the amount of rainfall, in millimetres, and the number of visitors each day. The results for 10 days are shown in the scatter diagram.

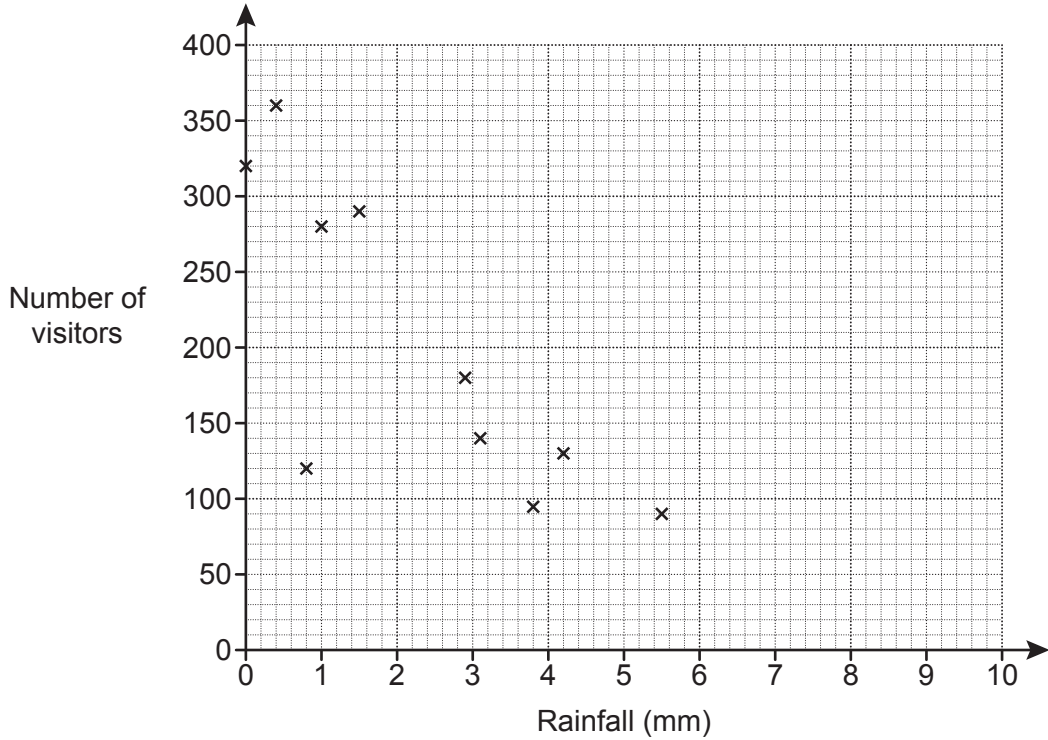

- (i) Circle the outlier on the scatter diagram. [1]
- (ii) The owner claims that he would expect around 320 visitors on a day with 2 mm of rainfall.

Does the scatter diagram support his statement?
Explain how you made your decision.

..... [2]

- (iii) Explain why the scatter diagram should not be used to estimate the number of visitors on a day with 9 mm of rainfall.

..... [1]

(b) The pie chart summarises information about the visitors to the tourist attraction on a different day.

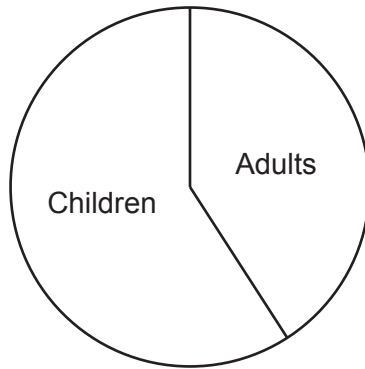

Explain why the pie chart cannot be used to work out how many adults visited on that day.

.....
..... [1]

17 (a) The scale of a map is 1 cm represents 25 m.

(i) The length of a path is 240 m.

Work out the length, in centimetres, of the path on the map.

(a)(i)cm [1]

(ii) The scale 1 cm represents 25 m can be written in the form 1 : k .

Find the value of k .

(ii) $k =$ [1]

(b) The scale drawing represents a park.

Scale: 1 cm represents 25 m

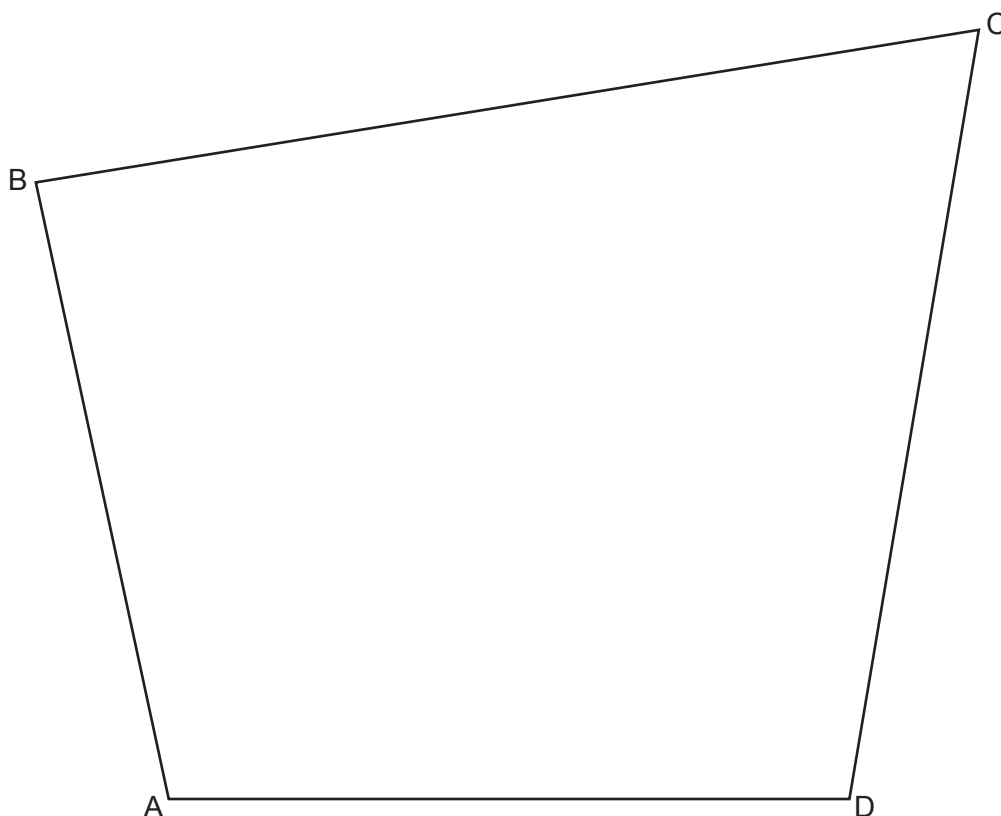

A new play area must be

- no more than 150 m from B
- closer to AD than to CD.

Construct and shade the region where the play area can be positioned.
Show all your construction lines.

[5]

- 18** A village has a population of 4200 and a population density of 700 people per km².
An estate is built next to the village.
The estate has an area of 2 km² and a population density of 800 people per km².

Work out the population density for the village and the estate together.

..... people per km² **[4]**

- 19** Two numbers have these properties.

- Both numbers are greater than 6.
- Their highest common factor (HCF) is 6.
- Their lowest common multiple (LCM) is 60.

Find the two numbers.

..... and **[3]**

20 (a) This is a fair 5-sided spinner.

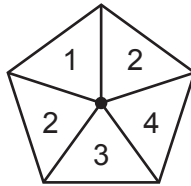

Ciara spins the spinner twice and records the product of the two scores.

(i) Complete the table.

		First spin				
		1	2	2	3	4
Second spin	1	1				
	2			4		
	2					
	3					
	4				12	

[2]

(ii) Find the probability that the product is a multiple of 3.

(a)(ii) [2]

(b) Ciara makes a different fair 5-sided spinner. She spins the spinner twice and records the product of the two scores.

Ciara says

The probability that the product is negative is 0.48.

Write numbers on the spinner below so that Ciara's statement is correct.

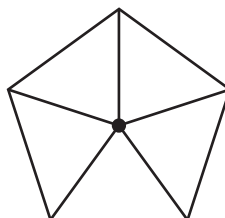

[3]

21 (a) Complete the table for $y = x^2 - 2x$.

x	-1	0	1	2	3	4
y	3	0	-1	0	3	

[1]

(b) Draw the graph of $y = x^2 - 2x$ for $-1 \leq x \leq 4$.

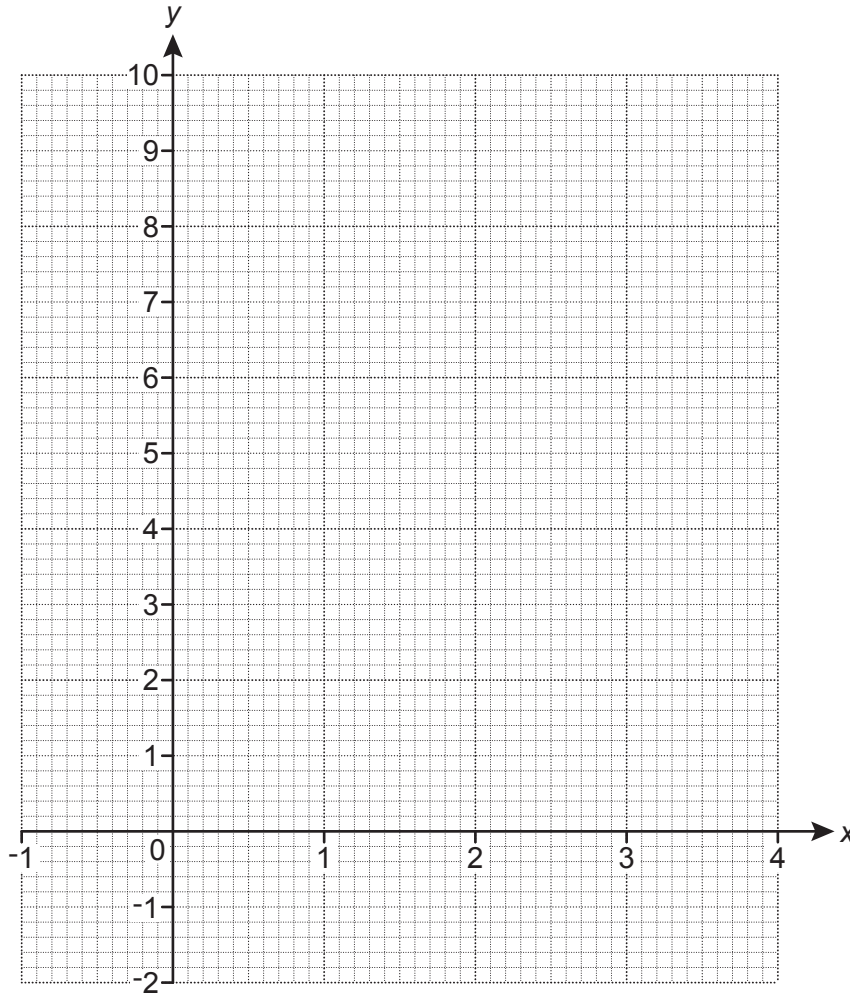

[2]

(c) Use your graph to solve $x^2 - 2x = 2$.

(c) [2]

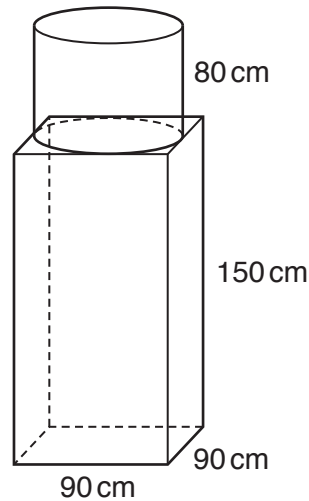

A sculpture is formed from a cylinder resting on top of a cuboid.
 The cylinder has radius 45 cm and height 80 cm.
 The cuboid measures 90 cm by 90 cm by 150 cm.

The sculpture is made of granite.
 The granite has a density of 2.7 g/cm^3 .

Calculate the total mass of the sculpture in tonnes.

.....tonnes [5]

END OF QUESTION PAPER

OCR

Oxford Cambridge and RSA

Copyright Information

OCR is committed to seeking permission to reproduce all third-party content that it uses in its assessment materials. OCR has attempted to identify and contact all copyright holders whose work is used in this paper. To avoid the issue of disclosure of answer-related information to candidates, all copyright acknowledgements are reproduced in the OCR Copyright Acknowledgements Booklet. This is produced for each series of examinations and is freely available to download from our public website (www.ocr.org.uk) after the live examination series.

If OCR has unwittingly failed to correctly acknowledge or clear any third-party content in this assessment material, OCR will be happy to correct its mistake at the earliest possible opportunity.

For queries or further information please contact the Copyright Team, First Floor, 9 Hills Road, Cambridge CB2 1GE.

OCR is part of the Cambridge Assessment Group; Cambridge Assessment is the brand name of University of Cambridge Local Examinations Syndicate (UCLES), which is itself a department of the University of Cambridge.