

Centre Number						Candidate Number				
Surname										
Other Names										
Candidate Signature										

For Examiner's Use	
Examiner's Initials	
Pages	Mark
3	
4 – 5	
6 – 7	
8 – 9	
10 – 11	
12 – 13	
14 – 15	
16 – 17	
18 – 19	
20 – 21	
22 – 23	
24 – 25	
TOTAL	



General Certificate of Secondary Education
Higher Tier
November 2014

Mathematics

43603H

Unit 3 Higher Tier

H

Wednesday 12 November 2014 9.00 am to 10.30 am

<p>For this paper you must have:</p> <ul style="list-style-type: none"> • a calculator • mathematical instruments. 	
---	--

Time allowed

- 1 hour 30 minutes

Instructions

- Use black ink or black ball-point pen. Draw diagrams in pencil.
- Fill in the boxes at the top of this page.
- Answer **all** questions.
- You must answer the questions in the spaces provided. Do not write outside the box around each page or on blank pages.
- Do all rough work in this book. Cross through any work that you do not want to be marked.
- If your calculator does not have a π button, take the value of π to be 3.14 unless another value is given in the question.

Information

- The marks for questions are shown in brackets.
- The maximum mark for this paper is 80.
- Quality of written communication is specifically assessed in questions 1, 7, 8 and 19. These questions are indicated with an asterisk (*).
- You may ask for more answer paper, graph paper and tracing paper. These must be tagged securely to this answer booklet.

Advice

- In all calculations, show clearly how you work out your answer.



N 0 V 1 4 4 3 6 0 3 H 0 1

Formulae Sheet: Higher Tier

Area of trapezium = $\frac{1}{2}(a+b)h$

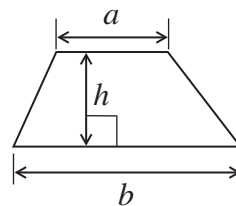

Volume of prism = area of cross-section \times length

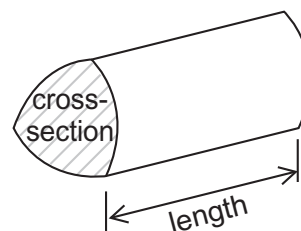

Volume of sphere = $\frac{4}{3}\pi r^3$

Surface area of sphere = $4\pi r^2$

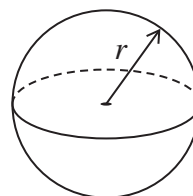

Volume of cone = $\frac{1}{3}\pi r^2 h$

Curved surface area of cone = $\pi r l$

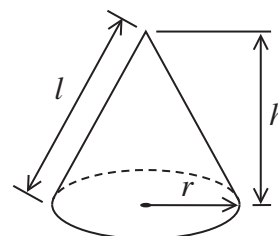

In any triangle ABC

Area of triangle = $\frac{1}{2}ab \sin C$

Sine rule $\frac{a}{\sin A} = \frac{b}{\sin B} = \frac{c}{\sin C}$

Cosine rule $a^2 = b^2 + c^2 - 2bc \cos A$

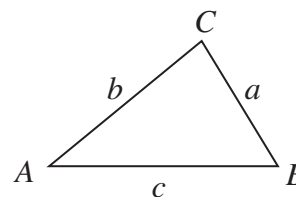

The Quadratic Equation

The solutions of $ax^2 + bx + c = 0$, where $a \neq 0$, are given by

$$x = \frac{-b \pm \sqrt{b^2 - 4ac}}{2a}$$



Answer **all** questions in the spaces provided.

***1** The length of a rectangle is x cm
The width of the rectangle is 3 cm **less** than the length.
The perimeter of the rectangle is 40 cm
Set up and solve an equation to work out the length of the rectangle.

[4 marks]

.....
.....
.....
.....
.....

Answer cm

Turn over for the next question

4

Turn over ►



2

Not drawn accurately

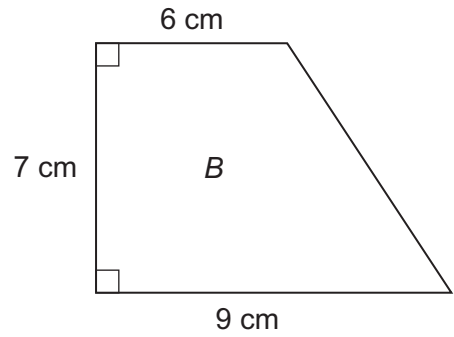
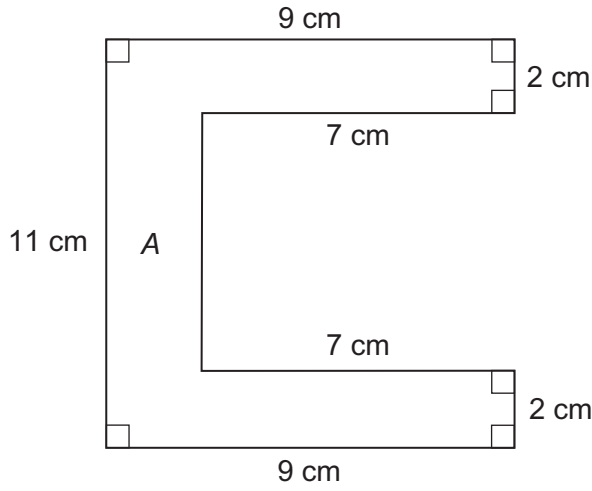

Which shape has the greater **area** and by how much?
You **must** show your working.

[5 marks]

.....

.....

.....

.....

.....

.....

.....

.....

.....

.....

Shape is greater by cm²



3 The diagram shows a road from *A* to *D*.
The distance from *A* to *D* is 35 miles

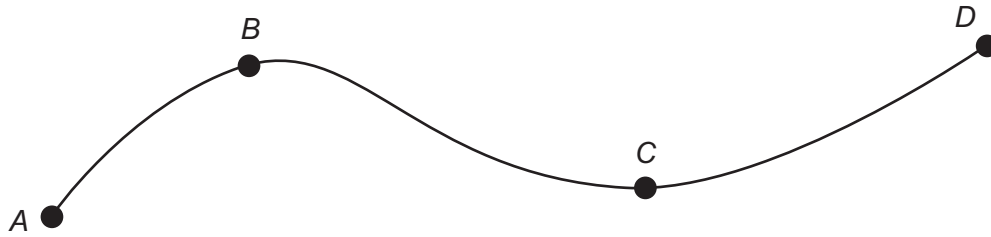

Each week

Amy drives from *A* to *D* and back to *A* **three** times
Bilal drives from *B* to *D* and back to *B* **five** times.

Bilal drives 60 miles **more** than Amy.

Work out the distance from *B* to *D*.

[3 marks]

.....

.....

.....

.....

Answer miles



- 4 The first diagram shows a kitchen wall with a window and two electric sockets.
The second diagram shows the length of each socket.

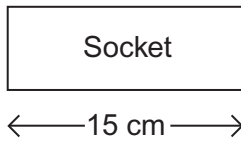
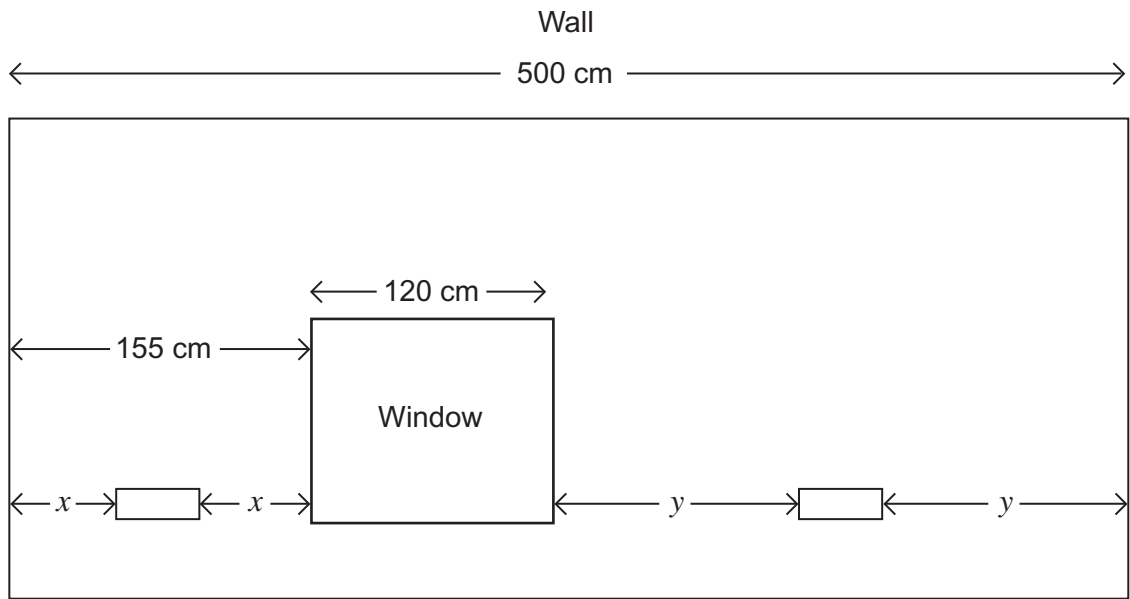

Not drawn accurately

Work out the lengths of x and y .

[5 marks]

.....

.....

.....

.....

.....

.....

.....

$x =$ cm

$y =$ cm



5 The diagram shows two aircraft, *A* and *B*, travelling in opposite directions.

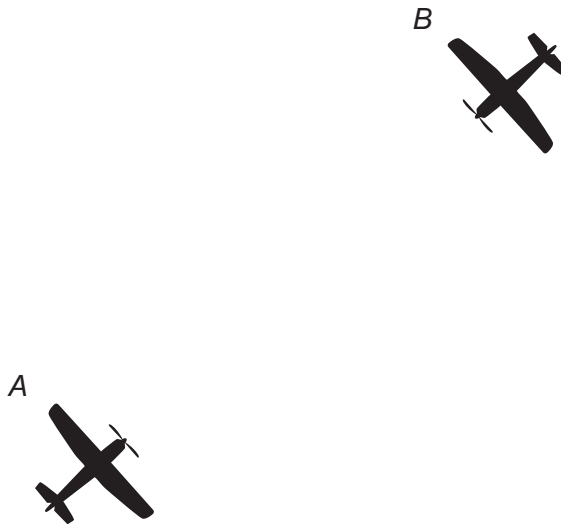

Aircraft *B* is on a bearing of 225°

5 (a) Work out the three-figure bearing of aircraft *A*.

[2 marks]

.....

.....

Answer $^\circ$

5 (b) Aircraft *B* turns 60° clockwise.

Work out the new three-figure bearing of aircraft *B*.
Circle your answer.

[1 mark]

- 105 $^\circ$ 165 $^\circ$ 285 $^\circ$ 345 $^\circ$



6 (a) The circumference of a circle is 25 cm

Work out the radius of the circle.

[2 marks]

.....
.....

Answer cm

6 (b) The diagram shows two identical circles and a square overlapping.

Each circle has a circumference of 32 cm

The sides of the square are radii to the circles.

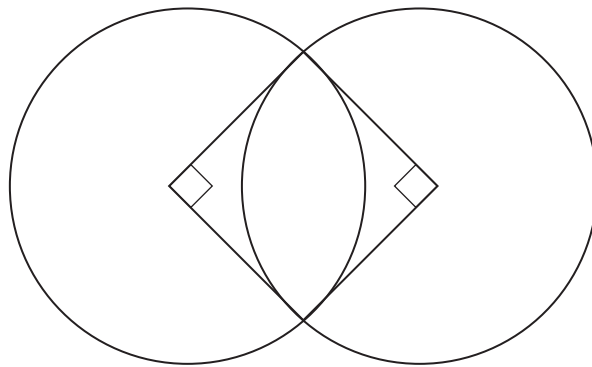

Not drawn
accurately

Work out the perimeter of the outer shape.



[3 marks]

.....
.....
.....
.....

Answer cm



*7 The diagram shows quadrilateral Q and triangle T joined together.

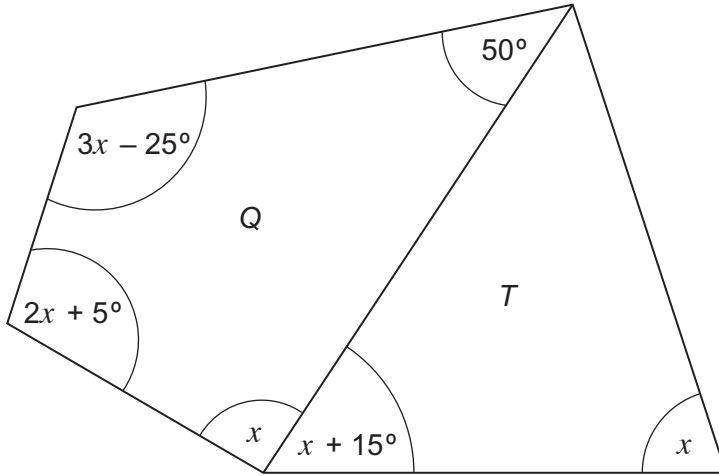

Not drawn accurately

What type of triangle is T?
You **must** show your working, which may be on the diagram.

[5 marks]

.....

.....

.....

.....

.....

.....

.....

.....

.....

Answer

10

Turn over ►



*8 Use trial and improvement to find the solution to $x^3 = 6000$

Give your answer to 1 decimal place.

[4 marks]

x	x^3	Comment

$x = \dots\dots\dots$



9

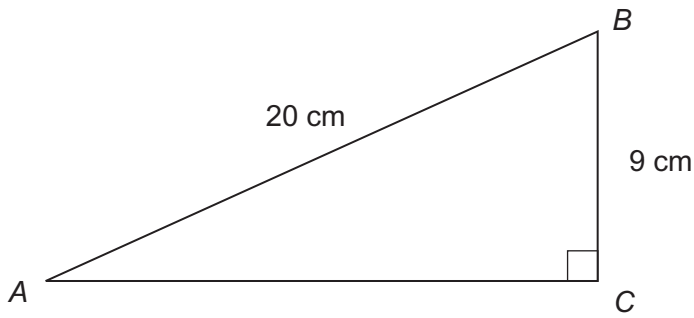

Not drawn
accurately

Work out the length AC.

[3 marks]

.....

.....

.....

.....

Answer cm

Turn over for the next question

7

Turn over ►



10 (a)

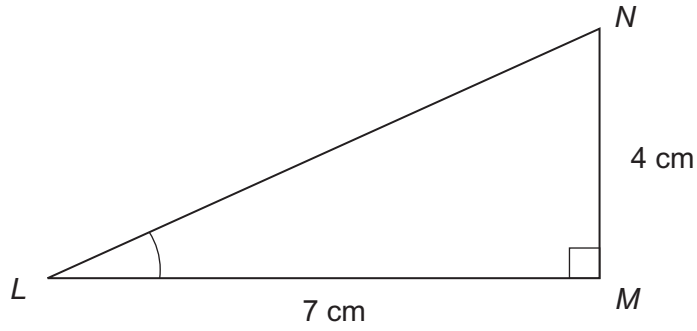

Not drawn
accurately

Work out the size of angle L .

[3 marks]

.....

.....

.....

.....

Answer degrees



10 (b)

Not drawn
accurately

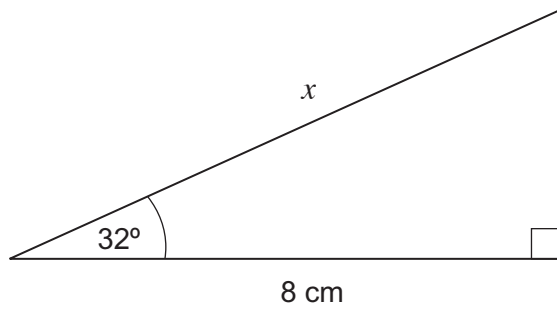

Work out x .

[3 marks]

.....

.....

.....

.....

Answer cm

Turn over for the next question

6

Turn over ►



11 Rectangle *B* is an enlargement of rectangle *A*.

Not drawn accurately

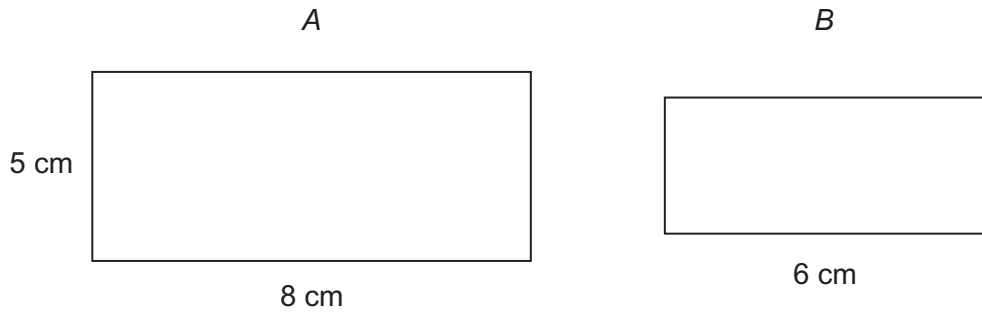

11 (a) Write down the scale factor of the enlargement from rectangle *A* to rectangle *B*.

[1 mark]

Answer

11 (b) Work out the ratio area of rectangle *A* : area of rectangle *B*

Give your answer in simplest form.

[3 marks]

.....

.....

.....

.....

Answer :



12 A cube is cut into four cuboids.

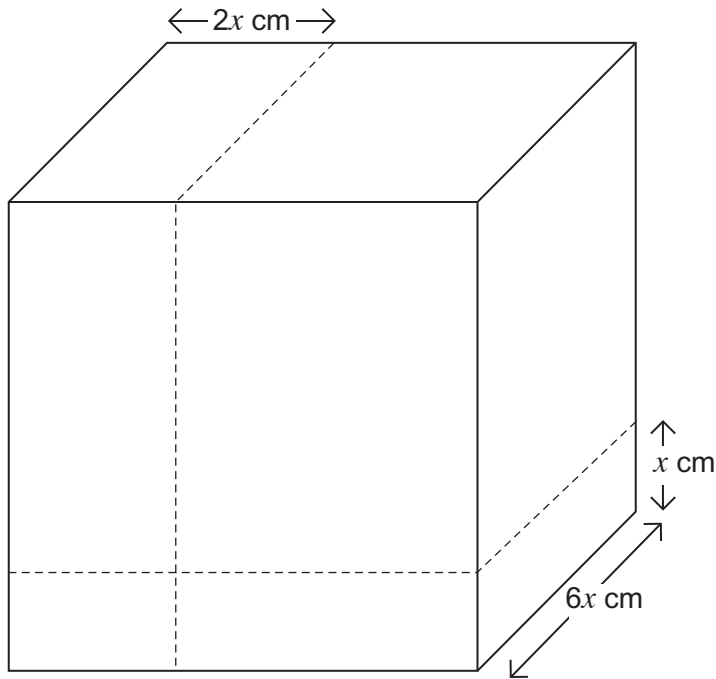

Write the volume of the **smallest** cuboid as a fraction of the volume of the cube.
Give your answer in its simplest form.

[3 marks]

.....

.....

.....

.....

.....

.....

Answer



13 (a) Lines $y = x - 1$ and $x = 2$ are shown on the grid.

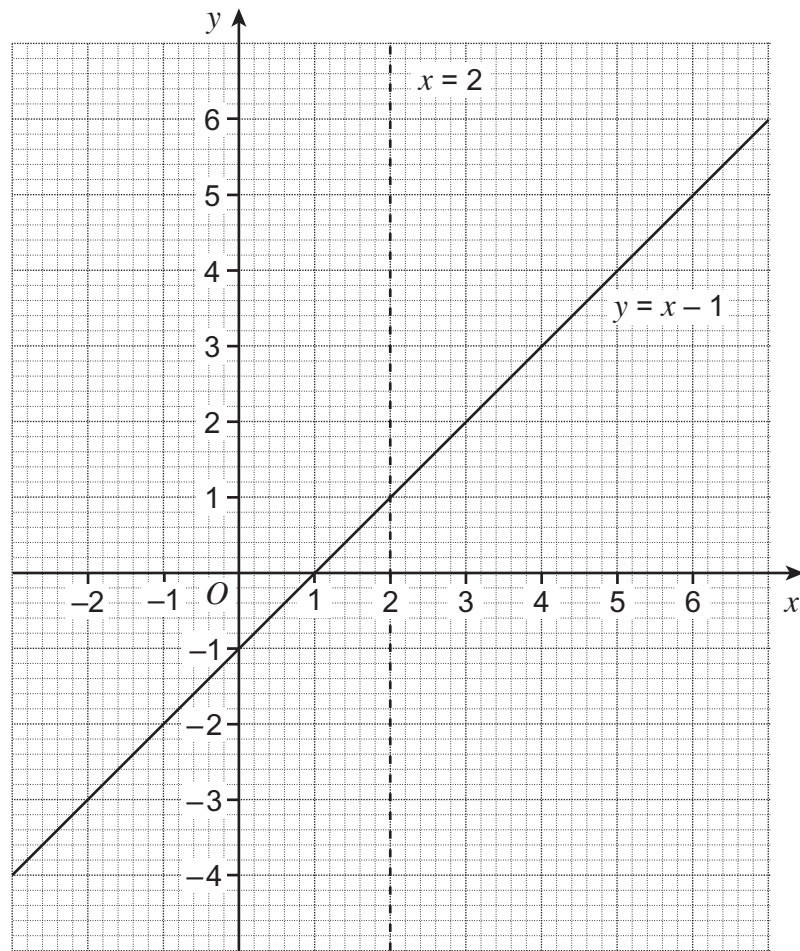

Draw the reflection of line $y = x - 1$ in the line $x = 2$

[1 mark]



13 (b) Work out the equation of the reflected line.

[2 marks]

.....

.....

.....

Answer

Turn over for the next question

3

Turn over ►



14 The diagram shows a sector of a circle with radius 9.2 cm

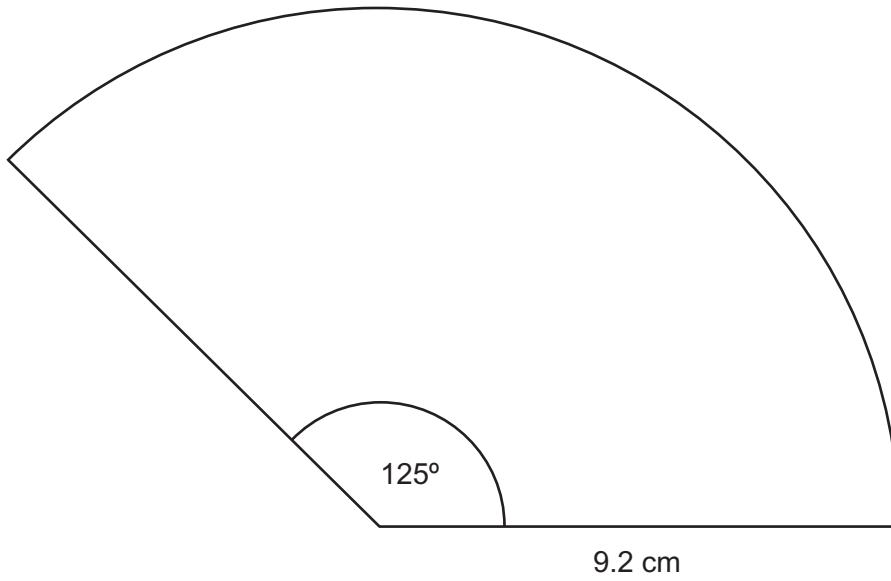

Not drawn
accurately

14 (a) Work out the area of the sector.

[3 marks]

.....

.....

.....

.....

.....

.....

Answer cm²



14 (b) Work out the area of the shaded segment.

Not drawn
accurately

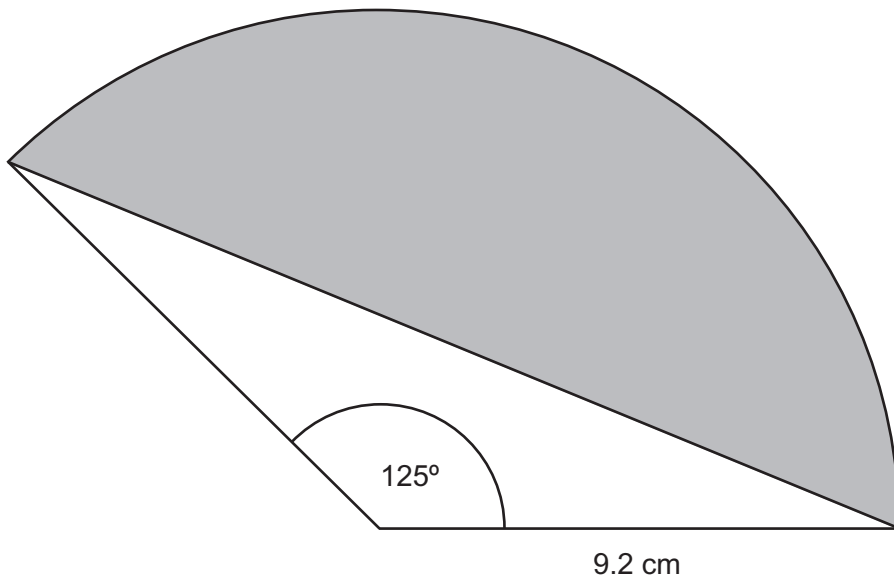

[3 marks]

.....

.....

.....

.....

.....

.....

.....

Answer cm²

6

Turn over ►



15 A, B, C, D and E are points on a circle.
 AC is parallel to ED .

Not drawn
accurately

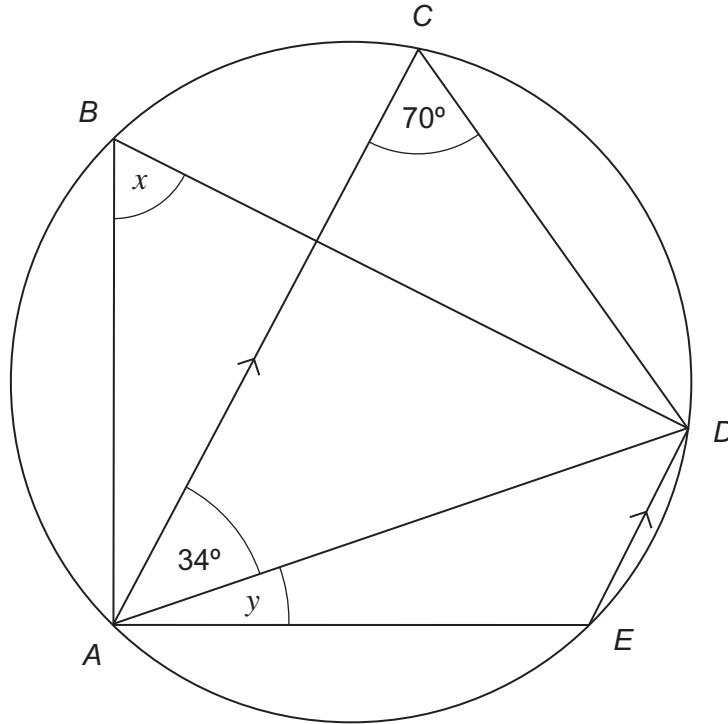

15 (a) Write down the size of angle x .

[1 mark]

Answer degrees

15 (b) Work out the size of angle y .

[3 marks]

.....

.....

.....

.....

Answer degrees



16

Not drawn accurately

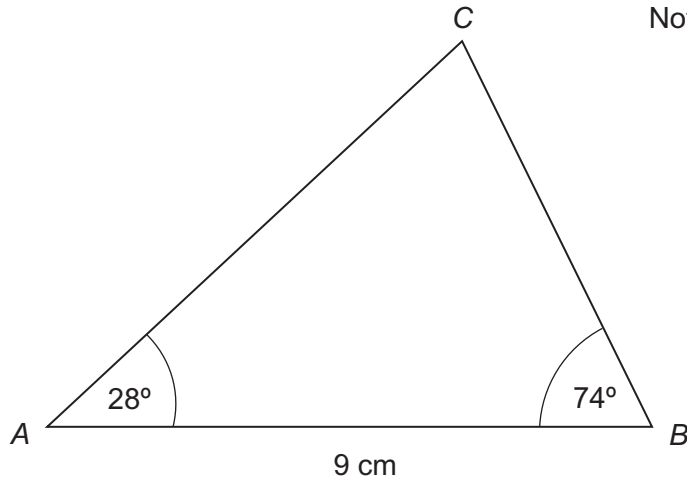

Work out the length of *BC*.

[4 marks]

.....

.....

.....

.....

.....

.....

.....

.....

.....

Answer cm

8

Turn over ►



- 17 On the opposite page are five sketch graphs that show depth of water against time. Water is poured into each container at a steady rate.

For each part match the container to its graph opposite.

17 (a)

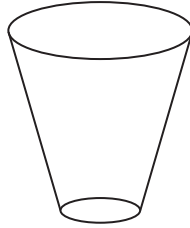

Circle your answer.

[1 mark]

A

B

C

D

E

17 (b)

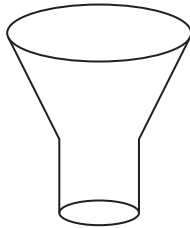

Circle your answer.

[1 mark]

A

B

C

D

E

17 (c)

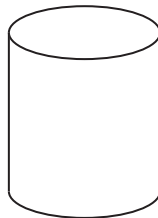

Circle your answer.

[1 mark]

A

B

C

D

E



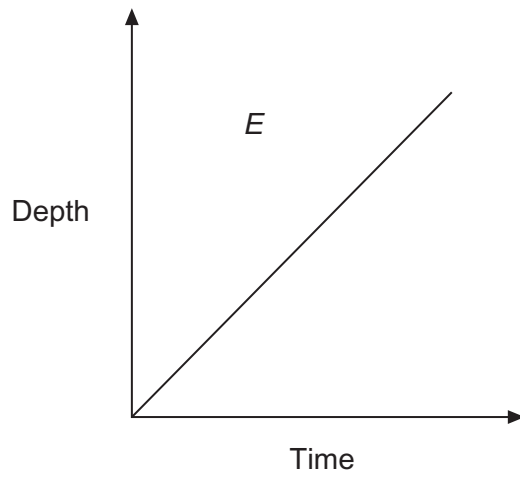
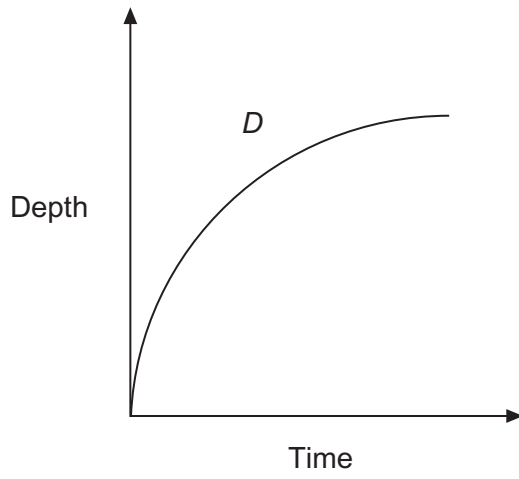
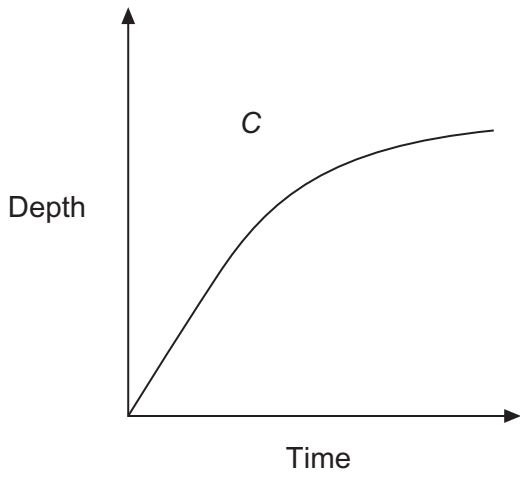
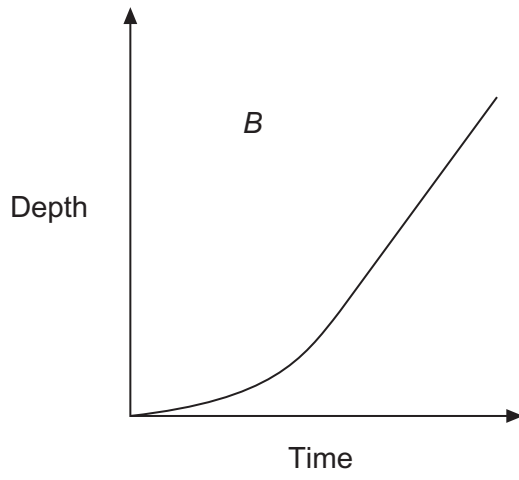
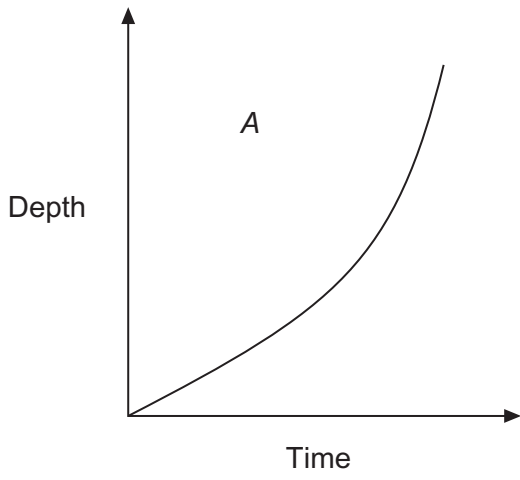

18 Work out the points of intersection of the graphs of

$$y = (x + 3)(x - 5)$$

and $y = 4x + 1$

[6 marks]

.....

.....

.....

.....

.....

.....

.....

.....

.....

.....

.....

.....

.....

.....

.....

.....

.....

.....

.....

.....

.....

.....

Answer



- 19** $ABCDE$ is a pentagon.
 M is the midpoint of BC .
 N is the midpoint of CD .

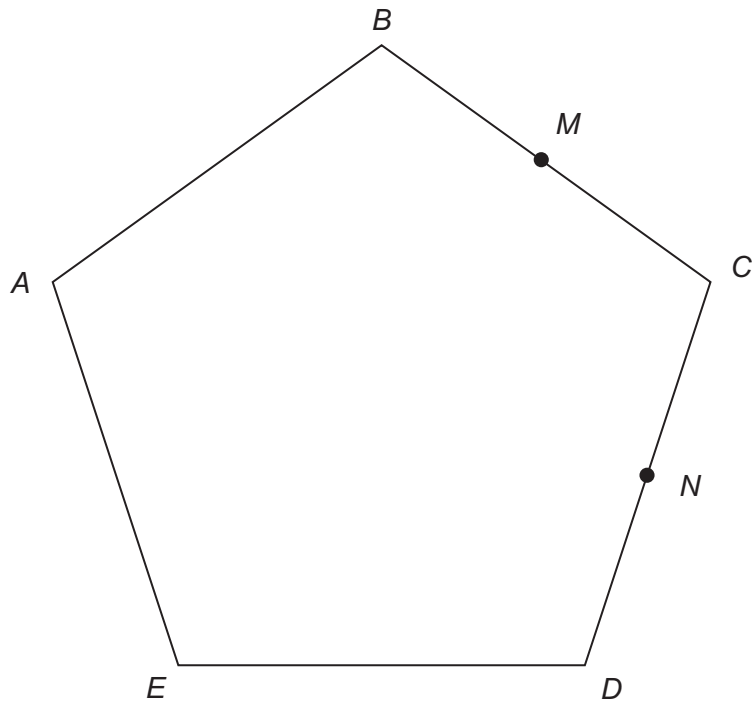

$$\vec{BC} = \mathbf{x}$$

$$\vec{CD} = \mathbf{y}$$

- *19 (a)** Show that MN is parallel to BD .

[3 marks]

.....

.....

.....

- 19 (b)** Write down the ratio $BD : MN$ in its simplest form.

[1 mark]

Answer :

END OF QUESTIONS

10



There are no questions printed on this page

**DO NOT WRITE ON THIS PAGE
ANSWER IN THE SPACES PROVIDED**



There are no questions printed on this page

**DO NOT WRITE ON THIS PAGE
ANSWER IN THE SPACES PROVIDED**



There are no questions printed on this page

**DO NOT WRITE ON THIS PAGE
ANSWER IN THE SPACES PROVIDED**

