

Please write clearly in block capitals.

Centre number

--	--	--	--	--

Candidate number

--	--	--	--

Surname

---

Forename(s)

---

Candidate signature

---

# GCSE MATHEMATICS

# F

Foundation Tier Unit 3 Geometry and Algebra

---

Tuesday 10 November 2015

Morning

Time allowed: 1 hour 30 minutes

## Materials

For this paper you must have:

- a calculator
- mathematical instruments.



## Instructions

- Use black ink or black ball-point pen. Draw diagrams in pencil.
- Answer **all** questions.
- You must answer the questions in the spaces provided. Do not write outside the box around each page or on blank pages.
- Do all rough work in this book. Cross through any work that you do not want to be marked.
- If your calculator does not have a  $\pi$  button, take the value of  $\pi$  to be 3.14 unless another value is given in the question.

## Information

- The marks for questions are shown in brackets.
- The maximum mark for this paper is 80.
- Quality of your written communication is specifically assessed in Questions 11, 12, 17 and 20. These questions are indicated with an asterisk (\*).
- You may ask for more answer paper, graph paper and tracing paper. These must be tagged securely to this answer booklet.

## Advice

- In all calculations, show clearly how you work out your answer.
- 



**Formulae Sheet: Foundation Tier**

**Area of trapezium** =  $\frac{1}{2}(a+b)h$

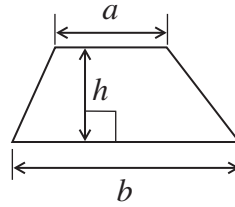

**Volume of prism** = area of cross section  $\times$  length

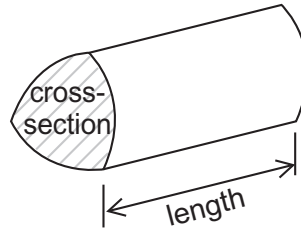

Answer **all** questions in the spaces provided.

**1 (a)** Shade 25% of this centimetre grid.

**[1 mark]**

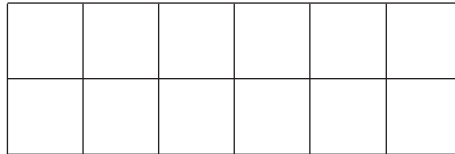

**1 (b)** Work out the fraction of this centimetre grid that is shaded.  
Give your answer in its simplest form.

**[2 marks]**

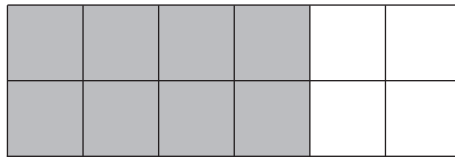

.....

.....

.....

.....

Answer .....



2 Here are some units.

metres	kilograms	litres	millilitres
kilometres	centimetres	grams	tonnes

Choose the best unit to complete each sentence.

**[3 marks]**

The length of a classroom is measured in .....

The mass of an average human is measured in .....

The amount of water in a full bath is measured in .....



- 3 The diagram shows five lines on a square grid.

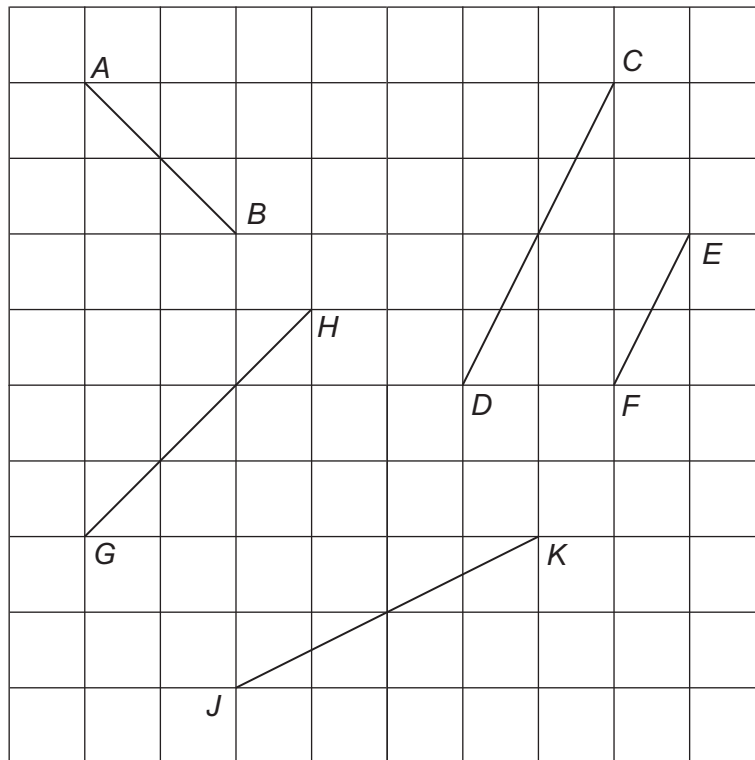

- 3 (a) Which **two** lines are parallel?  
Circle your answers.

[1 mark]

*AB*      *CD*      *EF*      *GH*      *JK*

- 3 (b) Which **two** lines are perpendicular?  
Circle your answers.

[1 mark]

*AB*      *CD*      *EF*      *GH*      *JK*

- 3 (c) Which **two** lines are the same length?  
Circle your answers.

[1 mark]

*AB*      *CD*      *EF*      *GH*      *JK*



4 (a)

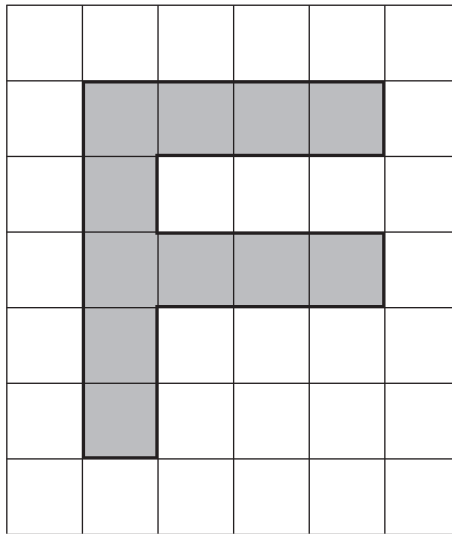

Work out the shaded area on this centimetre grid.  
State the units of your answer.

**[2 marks]**

.....

.....

.....

.....

Answer .....



- 4 (b)** Draw a rectangle on this centimetre grid with  
perimeter 18 cm

**[1 mark]**

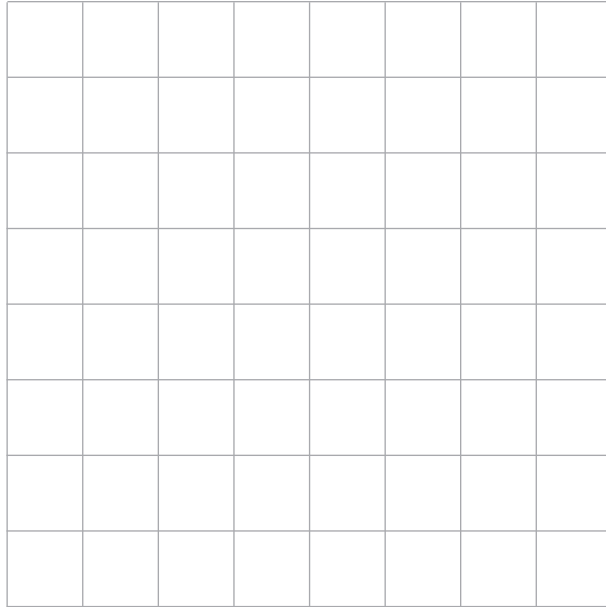

- 4 (c)** Draw a rectangle on this centimetre grid with  
perimeter 16 cm and area 12 cm<sup>2</sup>

**[2 marks]**

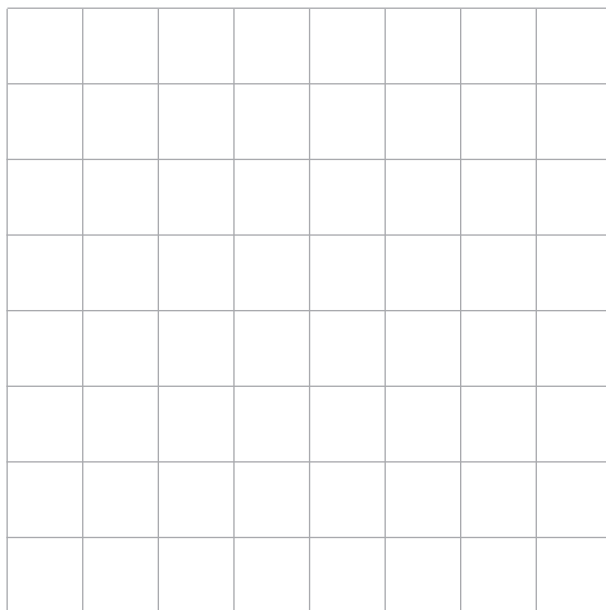

- 5 The diagram shows a half-arrow.

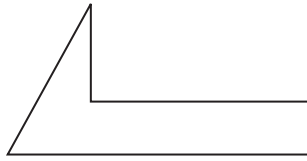

- 5 (a) Four half-arrows are joined to make this shape.

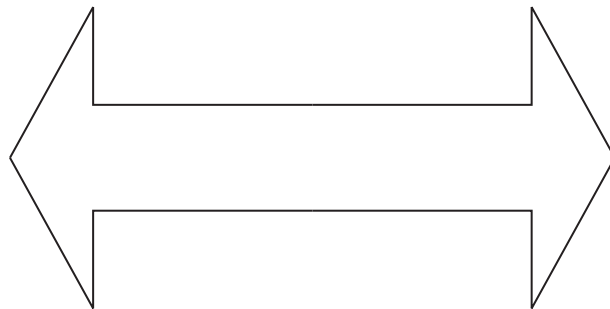

Draw **all** the lines of symmetry on the shape.

[2 marks]

- 5 (b) One of the four half-arrows is shaded in this diagram.

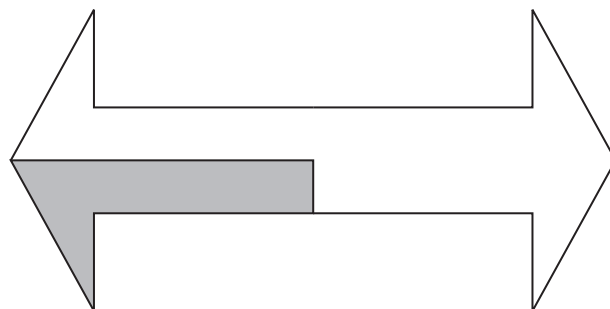

Shade **one more** half-arrow so that the diagram has one line of symmetry.

[1 mark]





5 (c) Two half-arrows are shaded in this diagram.

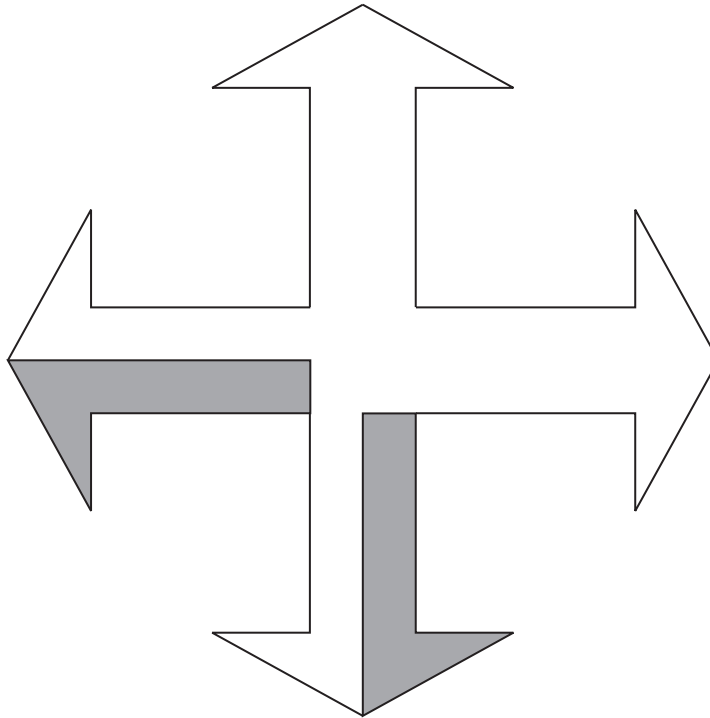

Shade **two more** half-arrows so that the diagram has  
rotational symmetry of order 4

[1 mark]

Turn over for the next question



6 Here is a diagram of a man standing by a building.

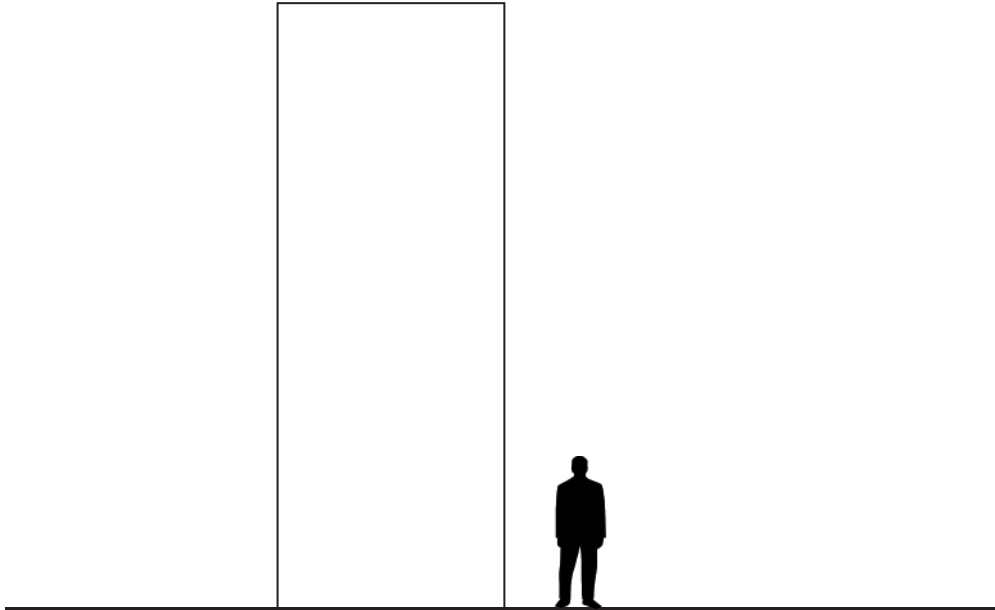

The actual height of the man is 1.7 m

Work out an estimate for the height of the building.

**[3 marks]**

.....

.....

.....

.....

Answer ..... m



7 The diagram shows the net of a cube.

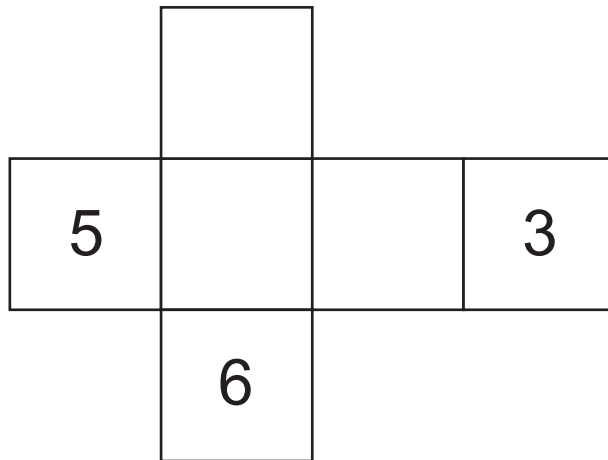

Put numbers on the blank faces so that opposite faces of the cube add up to 7 [2 marks]

8 5 miles = 8 kilometres  
Which is longer, 26 miles or 45 km?  
You **must** show your working.

[2 marks]

.....

.....

.....

.....

Answer .....



**9** An adult ticket costs £65.50  
A child ticket costs £35.25

**9 (a)** Kate has £105  
She buys one adult ticket and one child ticket.

How much money does she have left?

**[2 marks]**

.....  
.....  
.....

Answer £ .....

**9 (b)** Gina buys 5 tickets.  
She pays exactly £267

How many of each type of ticket does she buy?

**[2 marks]**

.....  
.....  
.....  
.....  
.....  
.....  
.....

Adult .....

Child .....



10

Construct an accurate scale drawing of this triangle.

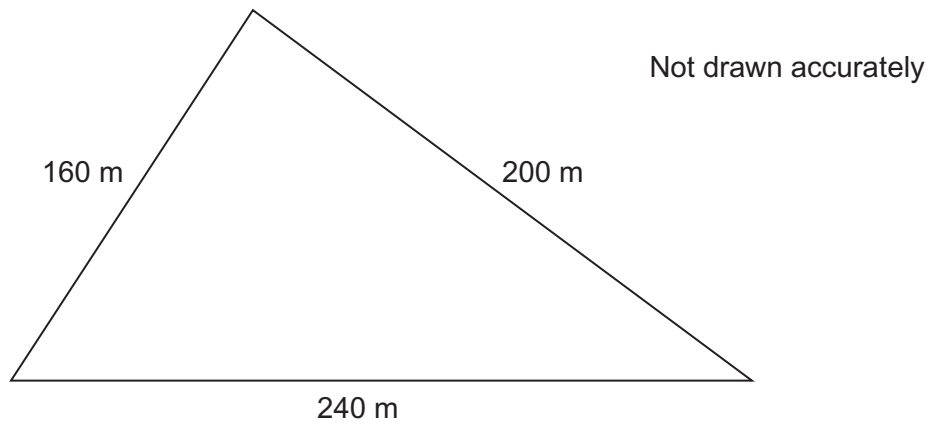

Use the scale 1 cm represents 20 m

The base has been drawn for you.

**[3 marks]**

Scale: 1 cm represents 20 m

7

Turn over ►



11 (a) The diagram shows a square.

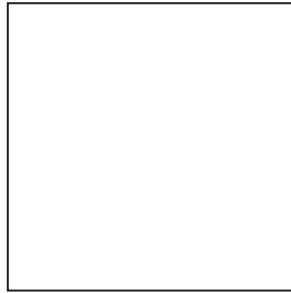

Not drawn accurately

$(4x + 3)$  cm

Work out the perimeter of the square when  $x = 4.5$

**[3 marks]**

.....

.....

.....

.....

.....

Answer ..... cm



**\*11 (b)** The diagram shows a triangle.

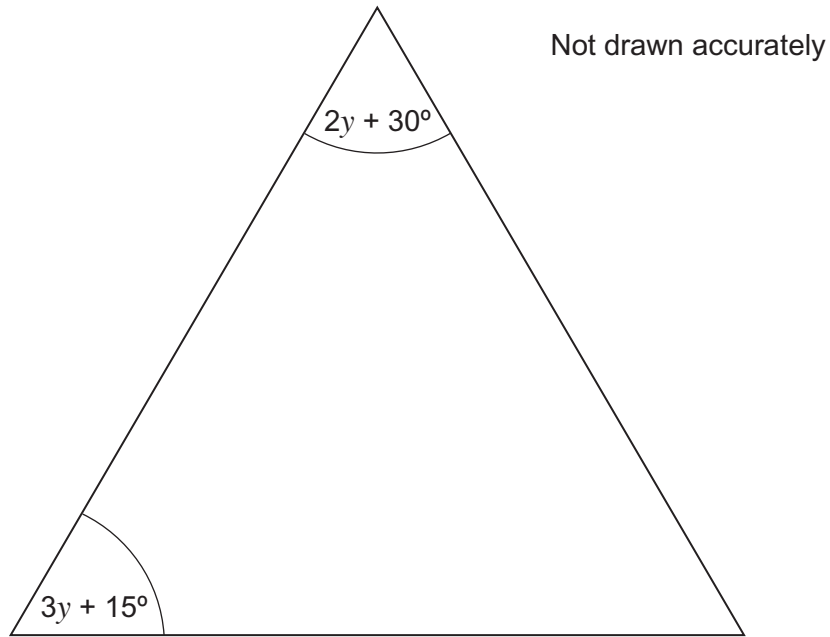

Show that the triangle is equilateral when  $y = 15^\circ$

**[3 marks]**

.....

.....

.....

.....

.....

.....



**\*12**

Here is a map.

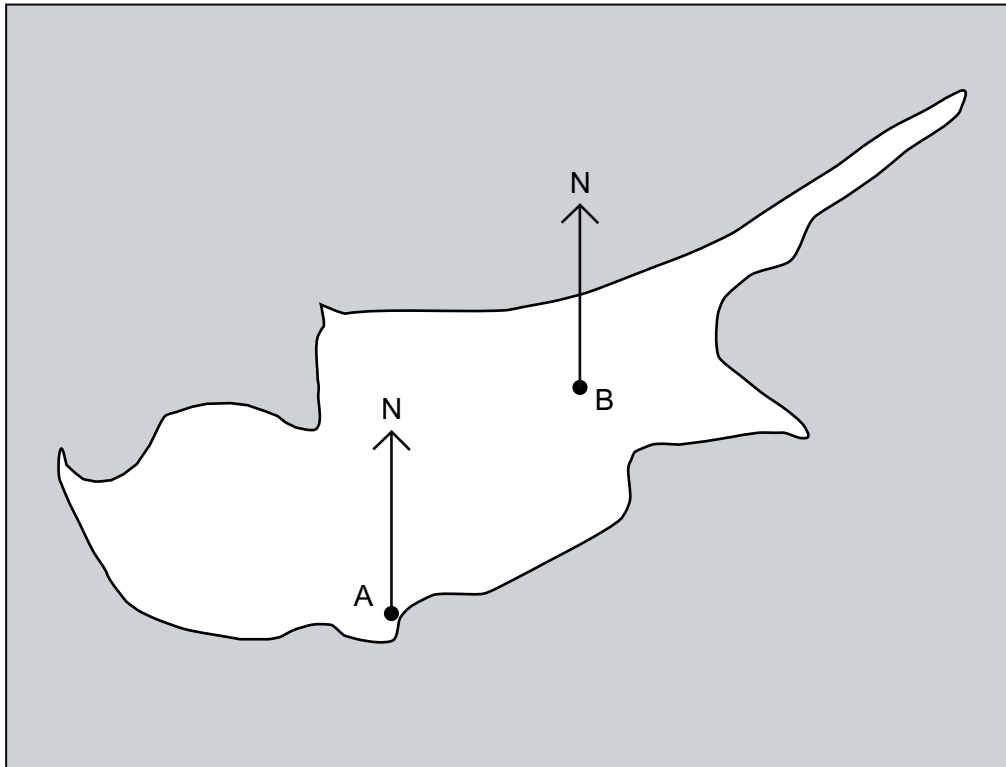

Measure and write down the three-figure bearing of B from A.

**[2 marks]**

Answer .....°





13 An isosceles triangle and a quadrilateral are joined to make this shape.

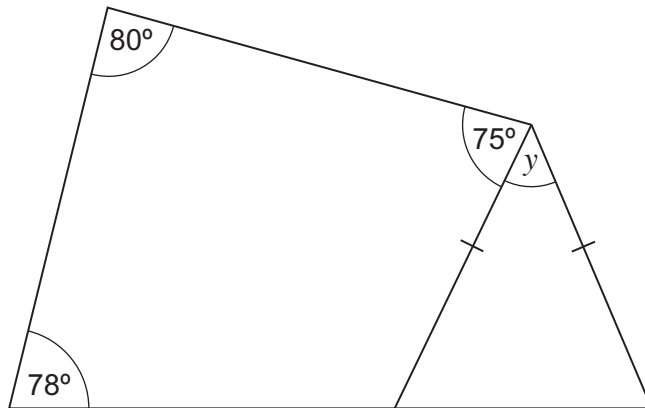

Not drawn  
accurately

The base of the shape is a straight line.

Work out the size of angle  $y$ .

[4 marks]

.....

.....

.....

.....

.....

.....

.....

.....

.....

Answer ..... degrees



- 14** The diagram shows a rectangle with dots on two sides.  
 The coordinates of  $A$ ,  $C$  and  $E$  are shown in the diagram.  
 $AC = DF$

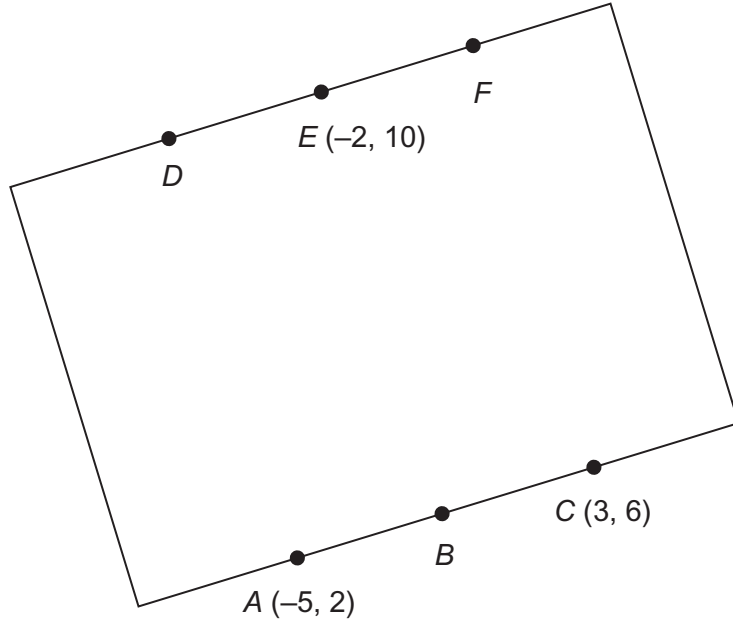

Not drawn  
accurately

The dots on each side are equally spaced.  
 Work out the coordinates of  $B$ ,  $D$  and  $F$ .

**[4 marks]**

.....  
 .....  
 .....  
 .....

$B$  ( ..... , ..... )

$D$  ( ..... , ..... )

$F$  ( ..... , ..... )



15 Work out the area of this pentagon.

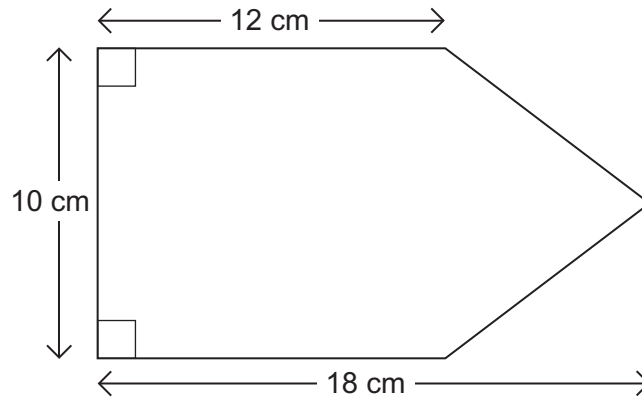

Not drawn accurately

[3 marks]

.....

.....

.....

.....

.....

.....

Answer ..... cm<sup>2</sup>

Turn over for the next question



16 (a) Enlarge this shape by scale factor 2 with centre of enlargement point  $P$ .

[3 marks]

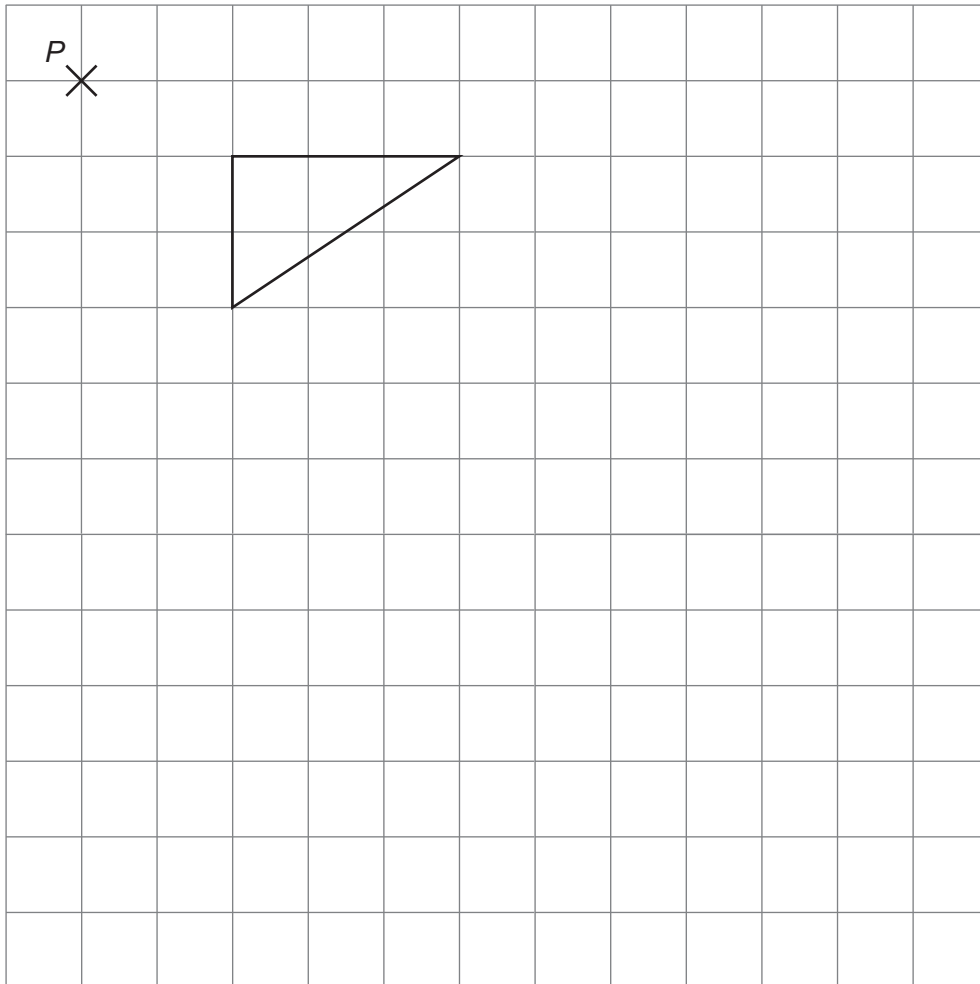

16 (b) Describe fully the **single** transformation that maps shape A to shape B.

[3 marks]

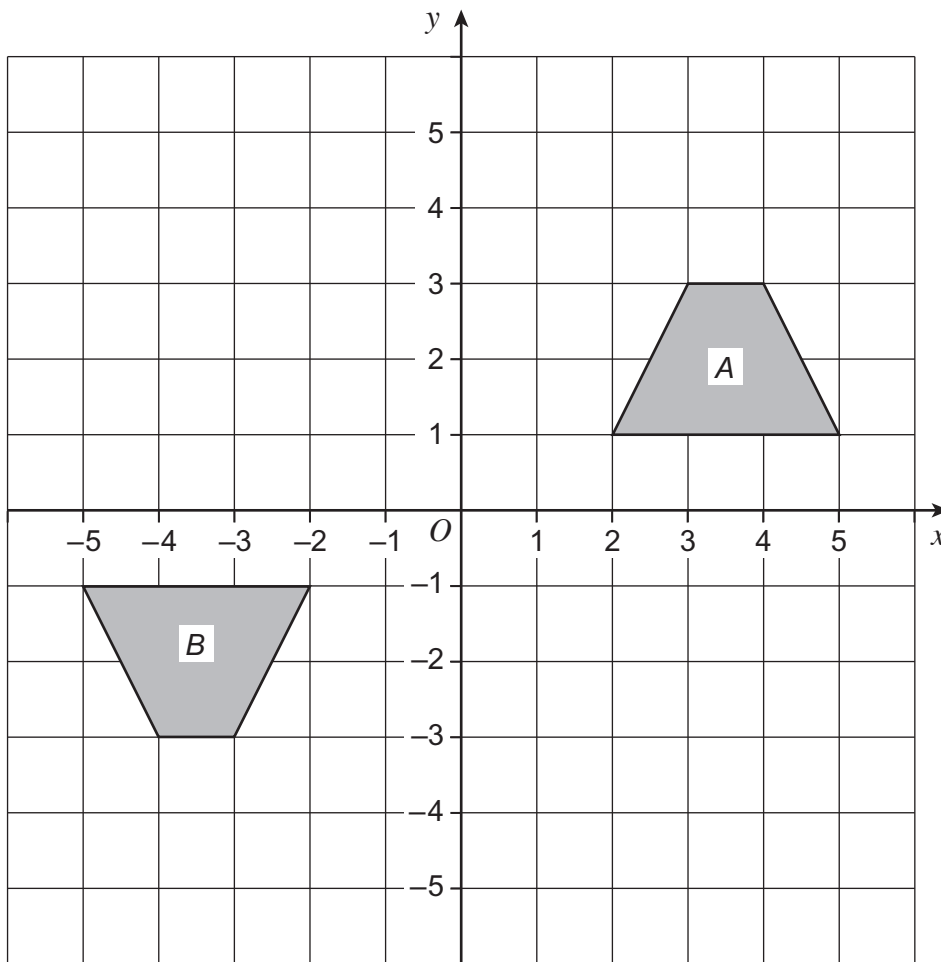

.....

.....

.....



**\*17** A gardener uses this formula to work out how much he charges to make a lawn.

$$C = \frac{7(14 + A)}{3}$$

$C$  is the charge in £

$A$  is the area in  $\text{m}^2$

He makes a rectangular lawn measuring 12.5 m by 17.6 m

How much does he charge?

**[3 marks]**

.....

.....

.....

.....

.....

.....

Answer £ .....



18 The diagram shows a water tank in the shape of a cuboid.

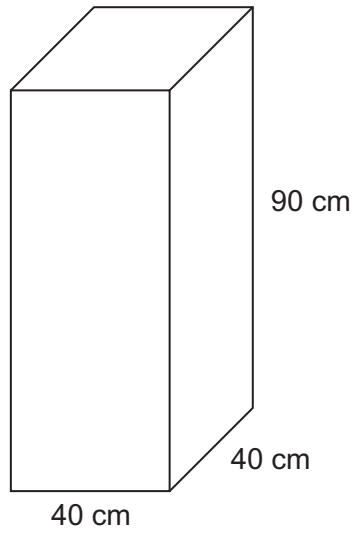

The tank is full of water.

1 litre = 1000 cm<sup>3</sup>

How many gallons of water are in the tank?

[4 marks]

.....

.....

.....

.....

.....

.....

Answer ..... gallons

7

Turn over ►



- 19 The diagram shows three straight lines.

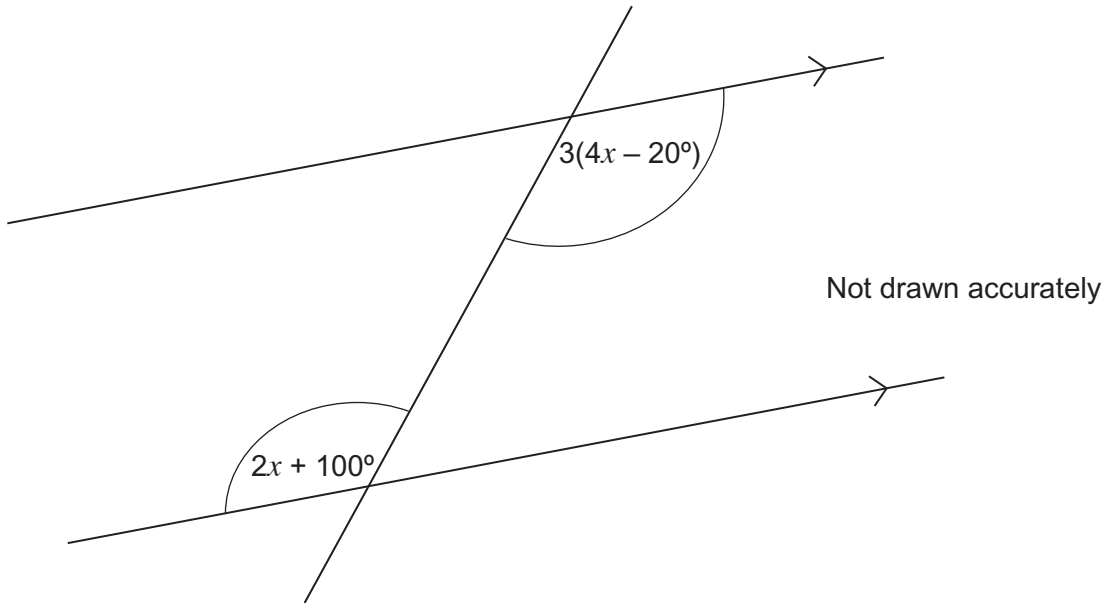

- 19 (a) Which of the following describes the pair of angles marked?  
Circle your answer.

[1 mark]

Alternate

Corresponding

Interior

Vertically opposite





19 (b) Work out the value of  $x$ .

[4 marks]

.....

.....

.....

.....

.....

.....

.....

.....

$x =$  ..... degrees

Turn over for the next question

5

Turn over ►



\*20

Washing powder is sold in two sizes, 600 grams and 1500 grams.

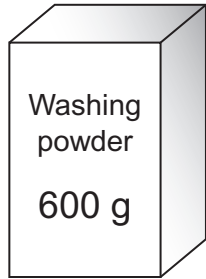

£3.30



Was £9.60  
Now 15% off

Which size is better value for money?  
You **must** show your working.

[6 marks]

.....

.....

.....

.....

.....

.....

.....

.....

.....

.....

Answer .....



21 The diagram shows a square and a circle.

Not drawn accurately

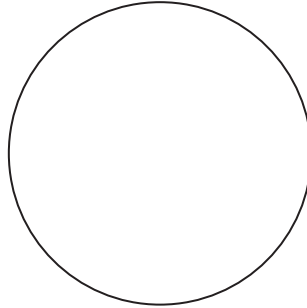
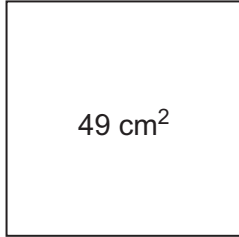

The **area** of the square is 49 cm<sup>2</sup>

The **perimeter** of the square is equal to the **circumference** of the circle.

Work out the radius of the circle.  
Give your answer to 1 decimal place.

[5 marks]

.....

.....

.....

.....

.....

.....

.....

.....

.....

.....

.....

.....

Answer ..... cm

END OF QUESTIONS



**There are no questions printed on this page**

**DO NOT WRITE ON THIS PAGE  
ANSWER IN THE SPACES PROVIDED**

**Copyright Information**

For confidentiality purposes, from the November 2015 examination series, acknowledgements of third party copyright material will be published in a separate booklet rather than including them on the examination paper or support materials. This booklet is published after each examination series and is available for free download from [www.aqa.org.uk](http://www.aqa.org.uk) after the live examination series.

Permission to reproduce all copyright material has been applied for. In some cases, efforts to contact copyright-holders may have been unsuccessful and AQA will be happy to rectify any omissions of acknowledgements. If you have any queries please contact the Copyright Team, AQA, Stag Hill House, Guildford, GU2 7XJ.

Copyright © 2015 AQA and its licensors. All rights reserved.

