

Centre Number						Candidate Number				
Surname										
Other Names										
Candidate Signature										

For Examiner's Use	
Examiner's Initials	
Pages	Mark
3	
4 – 5	
6 – 7	
8 – 9	
10 – 11	
12 – 13	
14 – 15	
16 – 17	
18 – 19	
20 – 21	
22 – 23	
TOTAL	



General Certificate of Secondary Education  
Foundation Tier  
November 2014

# Mathematics

43603F

Unit 3 Foundation Tier

F

Wednesday 12 November 2014 9.00 am to 10.30 am

<p><b>For this paper you must have:</b></p> <ul style="list-style-type: none"> <li>• a calculator</li> <li>• mathematical instruments.</li> </ul>	
---	--

### Time allowed

- 1 hour 30 minutes

### Instructions

- Use black ink or black ball-point pen. Draw diagrams in pencil.
- Fill in the boxes at the top of this page.
- Answer **all** questions.
- You must answer the questions in the spaces provided. Do not write outside the box around each page or on blank pages.
- Do all rough work in this book. Cross through any work that you do not want to be marked.
- If your calculator does not have a  $\pi$  button, take the value of  $\pi$  to be 3.14 unless another value is given in the question.

### Information

- The marks for questions are shown in brackets.
- The maximum mark for this paper is 80.
- Quality of your written communication is specifically assessed in questions 9, 11, 14 and 19. These questions are indicated with an asterisk (\*).
- You may ask for more answer paper, graph paper and tracing paper. These must be tagged securely to this answer booklet.

### Advice

- In all calculations, show clearly how you work out your answer.



**Formulae Sheet: Foundation Tier**

**Area of trapezium** =  $\frac{1}{2}(a+b)h$

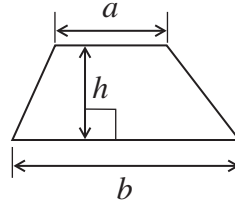

**Volume of prism** = area of cross section  $\times$  length

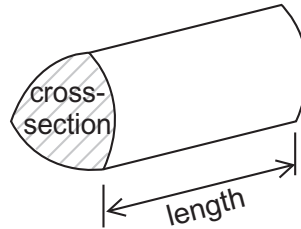

Answer **all** questions in the spaces provided.

- 1 The diagram shows shape *ABCDE*.

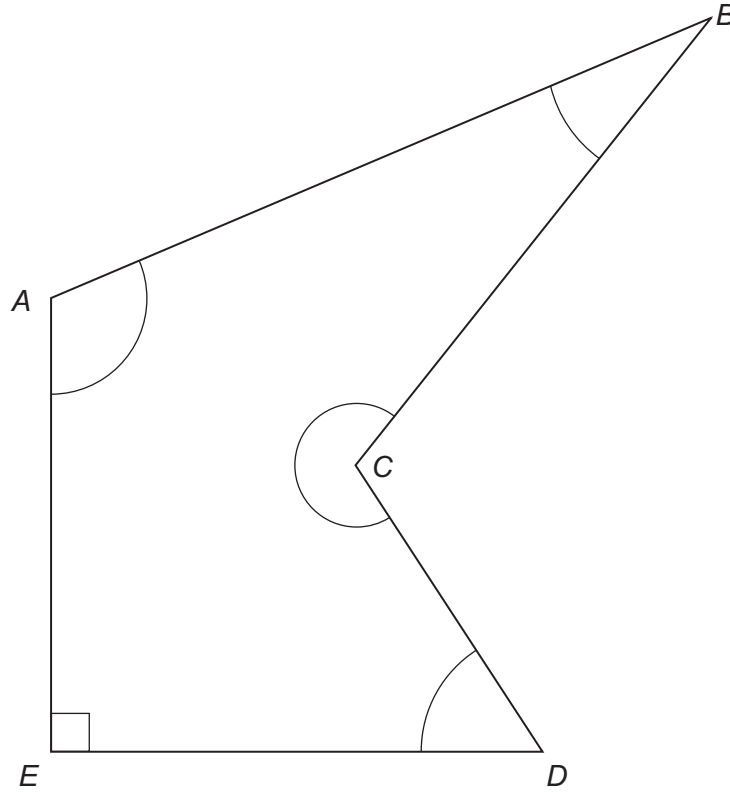

- 1 (a) Complete each sentence using a letter.

[3 marks]

Angle ..... is a right angle.

Angle ..... is an obtuse angle.

Angle ..... is a reflex angle.

- 1 (b) Circle the name of shape *ABCDE*.

[1 mark]

Hexagon

Octagon

Pentagon

Kite



2

A is the point (2, 9)

B is the point (6, 5)

ABC is a straight line.

$$AB = BC$$

Work out the coordinates of point C.

You may use the grid to help you.

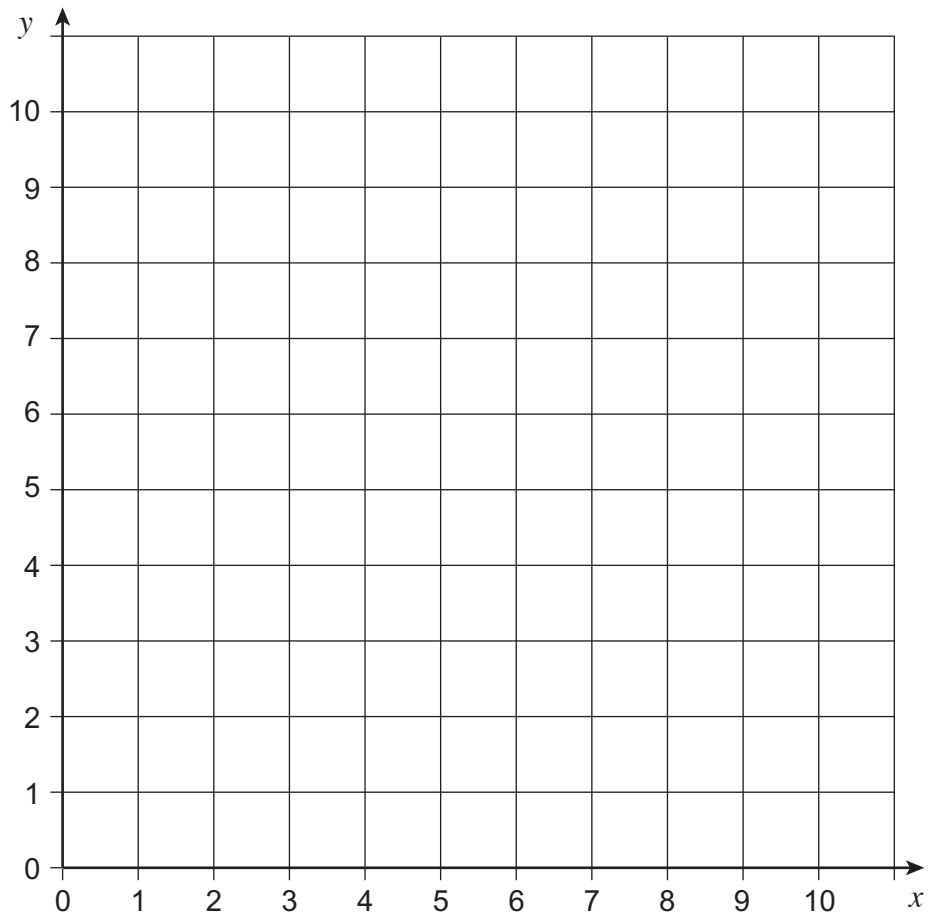
**[2 marks]**

Answer ( ..... , ..... )



**3** Here are some shapes.

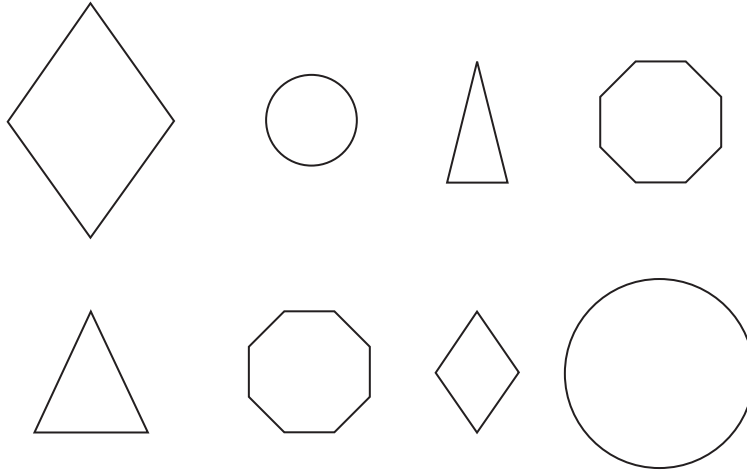

In each part, decide whether the shapes shown are similar, congruent or neither.

Circle your answers.

**3 (a)** The triangles are **[1 mark]**

similar

congruent

neither

**3 (b)** The circles are **[1 mark]**

similar

congruent

neither

**3 (c)** The rhombuses are **[1 mark]**

similar

congruent

neither

**3 (d)** The octagons are **[1 mark]**

similar

congruent

neither



4 A company makes tins in six different sizes.

For each increase in size, the capacity of the tin **doubles**.

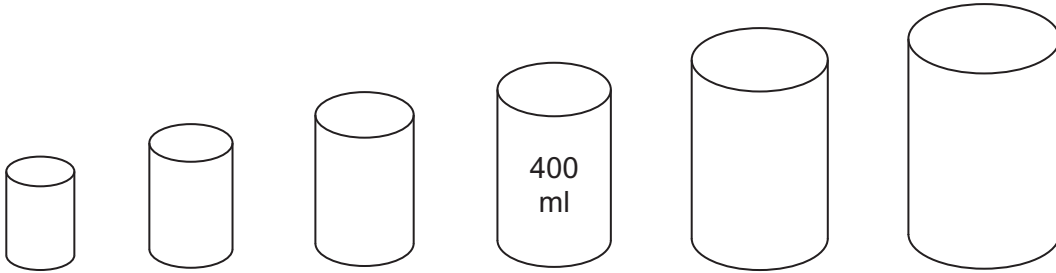

4 (a) Work out the capacity of the smallest tin.

[2 marks]

.....

Answer ..... ml

4 (b) Work out the capacity of the largest tin.  
Give your answer in litres.

[2 marks]

.....

.....

Answer ..... litres



**5** The diagram shows a road from *A* to *D*.  
 The distance from *A* to *D* is 35 miles.  
 The distance from *C* to *D* is 12 miles.

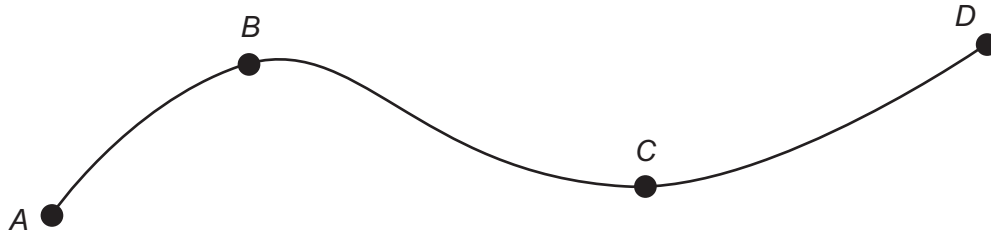

**5 (a)** Work out the distance from *A* to *C*.

**[1 mark]**

.....

Answer ..... miles

**5 (b)** Each day

Amy drives from *A* to *D* and back to *A*  
 Bilal drives from *B* to *D* and back to *B*.

Over **five** days Amy drives 80 miles **more** than Bilal.

Work out the distance from *B* to *D*.

**[3 marks]**

.....  
 .....  
 .....  
 .....

Answer ..... miles



6 Points  $A$  and  $B$  are shown on the grid.

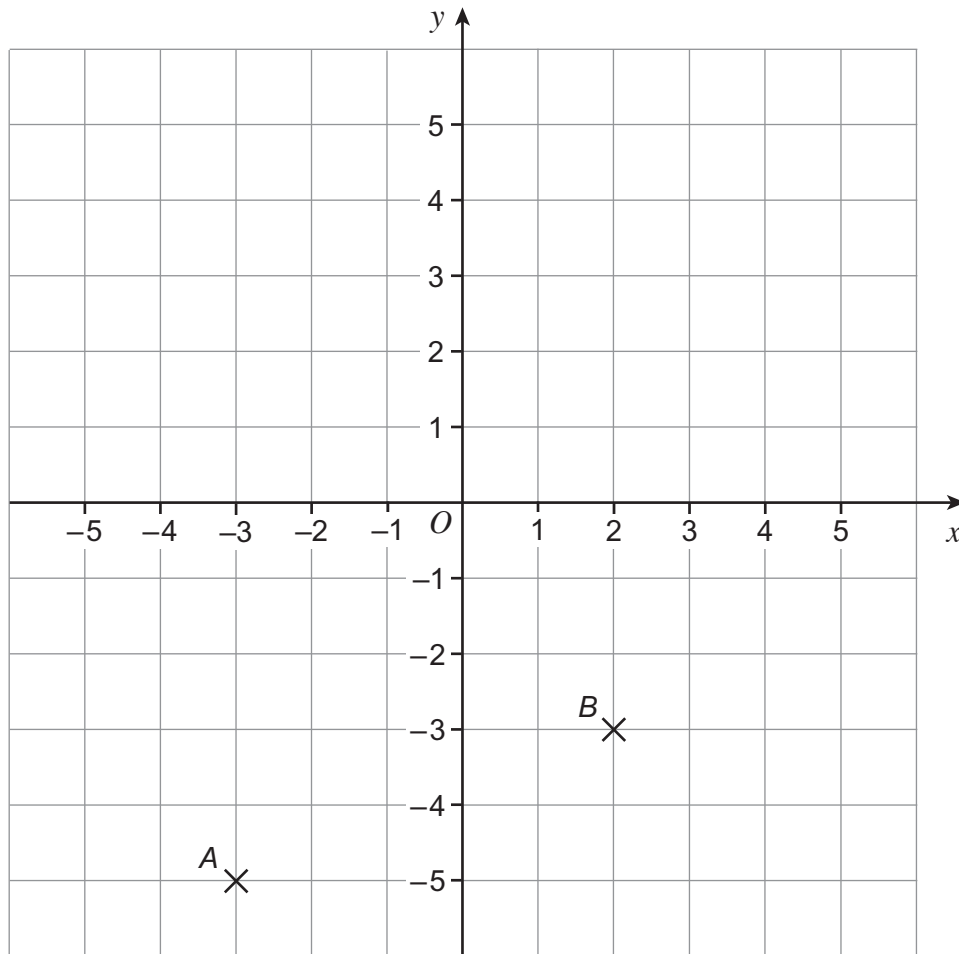

6 (a) Write down the coordinates of  $A$  and  $B$ .

[2 marks]

Answer  $A$  ( ..... , ..... )

$B$  ( ..... , ..... )

6 (b) Plot point  $C$  on the grid so that

the  $x$ -coordinate of  $C$  is less than the  $x$ -coordinate of  $A$

and the  $y$ -coordinate of  $C$  is positive and even.

[2 marks]





7 Rectangle *B* is an enlargement of rectangle *A*.

Not drawn accurately

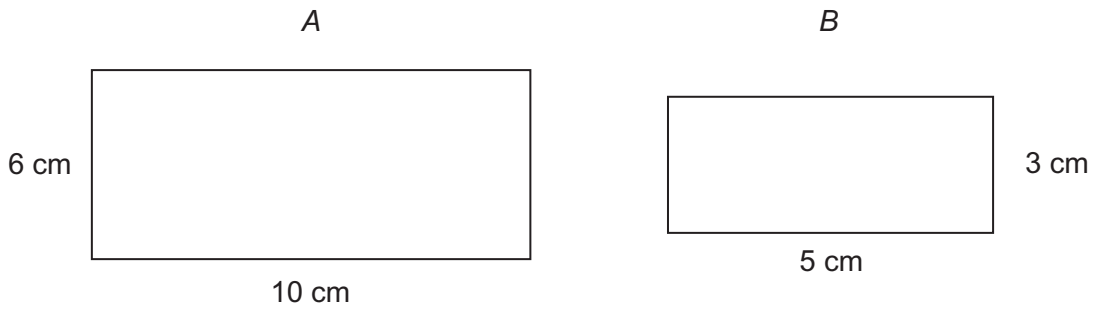

7 (a) Write down the scale factor of the enlargement from rectangle *A* to rectangle *B*. [1 mark]

Answer .....

7 (b) Work out the ratio area of rectangle *A* : area of rectangle *B*  
Give your answer in its simplest form. [3 marks]

.....

.....

.....

.....

Answer ..... : .....



8

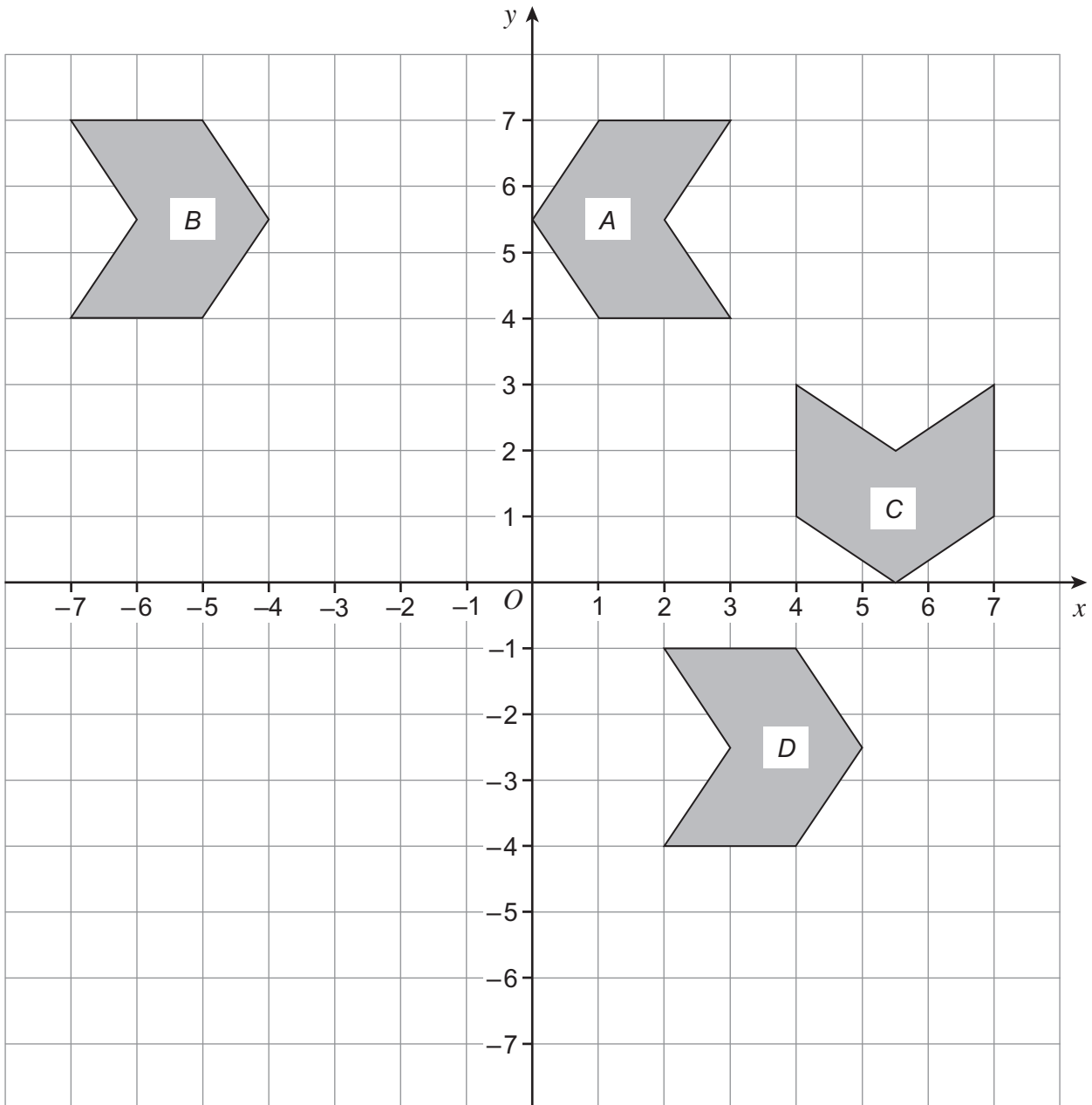

8 (a) On the grid draw the mirror line that reflects shape *A* to shape *B*.

[1 mark]

8 (b) On the grid draw the mirror line that reflects shape *A* to shape *C*.

[1 mark]



**8 (c)** Describe fully the single transformation that takes shape *B* to shape *D*.

**[2 marks]**

.....

.....

.....

**Turn over for the next question**

4
---

**Turn over ►**



**9** Gas bills are calculated from the number of kilowatt hours used.

**\*9 (a)** The first 2700 kilowatt hours of gas cost 8p each.  
Extra kilowatt hours of gas cost 5p each.

A family uses 5850 kilowatt hours of gas.

Work out their gas bill.

**[4 marks]**

.....

.....

.....

.....

.....

Answer £ .....

**9 (b)** Here is a formula for working out the profit a gas company makes from each bill.

$$\text{profit} = \text{bill} \times 0.07$$

What percentage of each gas bill is profit?

**[1 mark]**

Answer ..... %



10

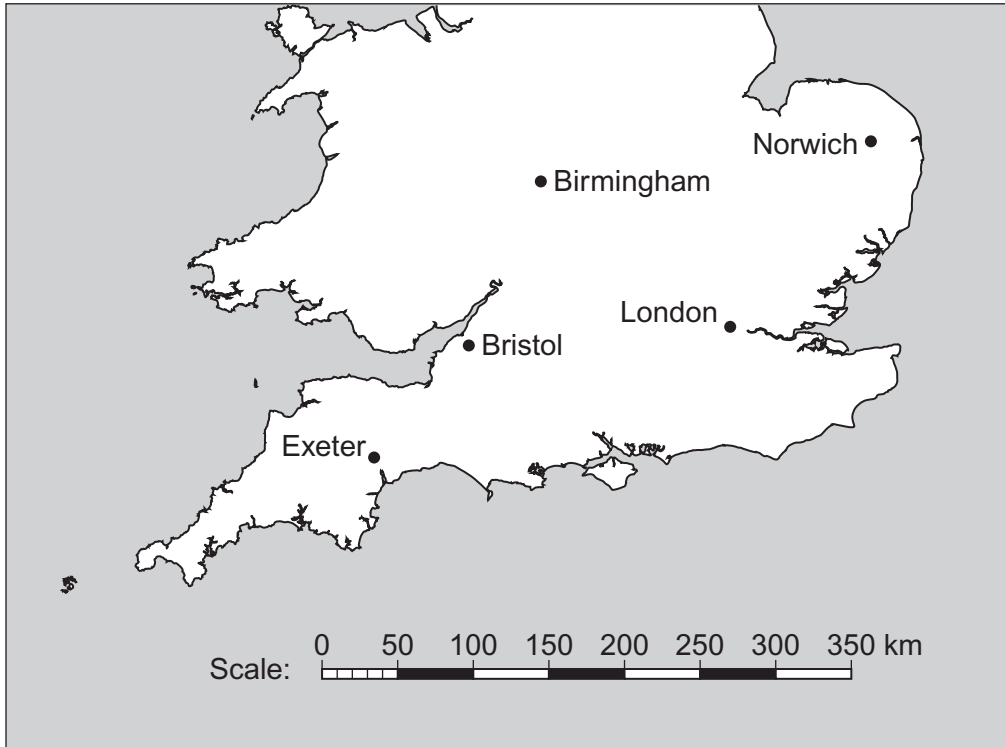

Work out the straight line distance between Exeter and Norwich.  
Give your answer in kilometres.

[3 marks]

.....

.....

.....

.....

Answer ..... km

8

Turn over ►



\*11 The diagram shows quadrilateral  $Q$  and triangle  $T$  joined together.

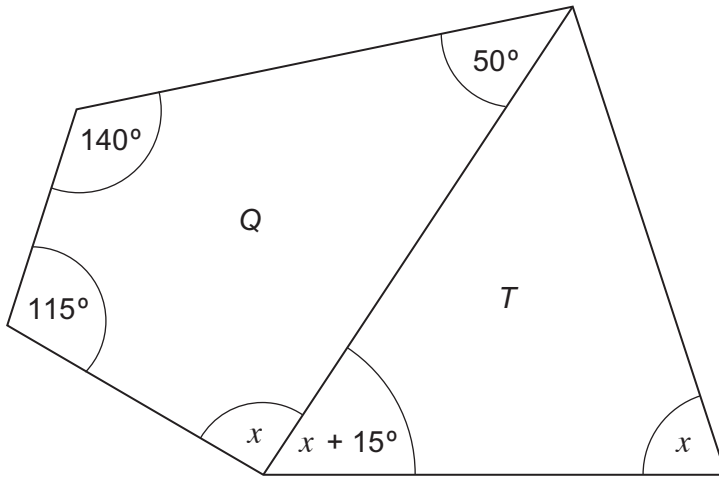

Not drawn accurately

What type of triangle is  $T$ ?

You **must** show your working, which may be on the diagram.

[5 marks]

.....

.....

.....

.....

.....

.....

Answer .....



12

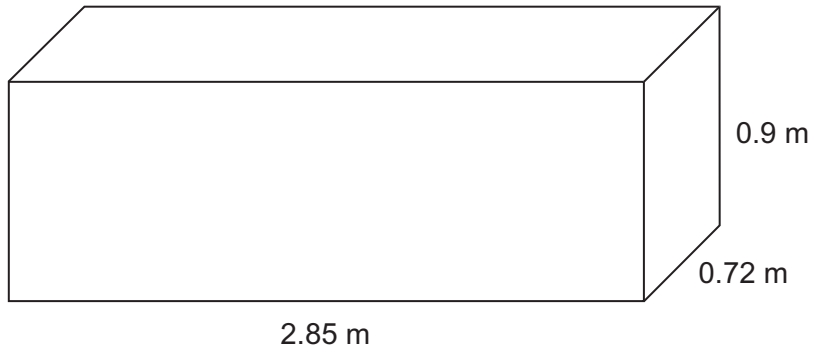

Work out the volume of the cuboid.  
State the units of your answer.

[3 marks]

.....

.....

.....

Answer .....

Turn over for the next question



**13** The diagram shows two aircraft, *A* and *B*, travelling in opposite directions.

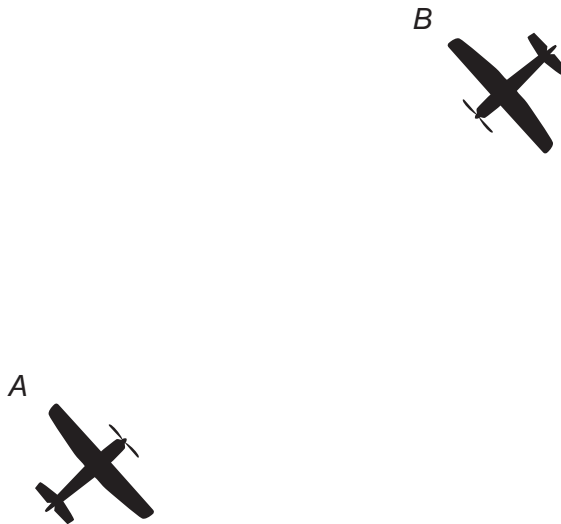

Aircraft *B* is on a bearing of  $225^\circ$  (South West).

**13 (a)** Work out the three-figure bearing of aircraft *A*.

**[2 marks]**

.....  
.....

Answer ..... $^\circ$

**13 (b)** Aircraft *B* turns  $60^\circ$  clockwise.

Work out the new three-figure bearing of aircraft *B*.  
Circle your answer.

**[1 mark]**

- 105 $^\circ$                       165 $^\circ$                       285 $^\circ$                       345 $^\circ$





**14** The length of a rectangle is  $x$  cm  
The width of the rectangle is 3 cm **less** than the length.

**14 (a)** Write down an expression for the width of the rectangle in terms of  $x$ . **[1 mark]**

Answer ..... cm

**\*14 (b)** The perimeter of the rectangle is 40 cm  
Set up and solve an equation to work out the length of the rectangle. **[4 marks]**

.....  
.....  
.....  
.....  
.....

Answer ..... cm

**Turn over for the next question**



15 (a) The circumference of a circle is 25 cm

Work out the radius of the circle.

[2 marks]

.....  
.....

Answer ..... cm

15 (b) The diagram shows two identical circles joined together.

Each circle has a circumference of 32 cm

The dashed lines are one-quarter of each circumference.

Not drawn accurately

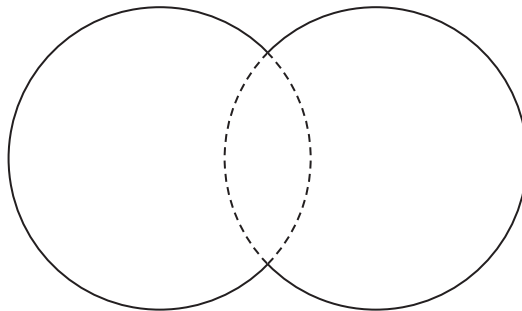

Work out the perimeter of the outer shape.



[3 marks]

.....  
.....  
.....  
.....

Answer ..... cm



- 16** The first diagram shows a kitchen wall with a window and two electric sockets.  
The second diagram shows the length of each socket.

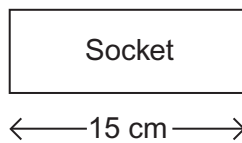
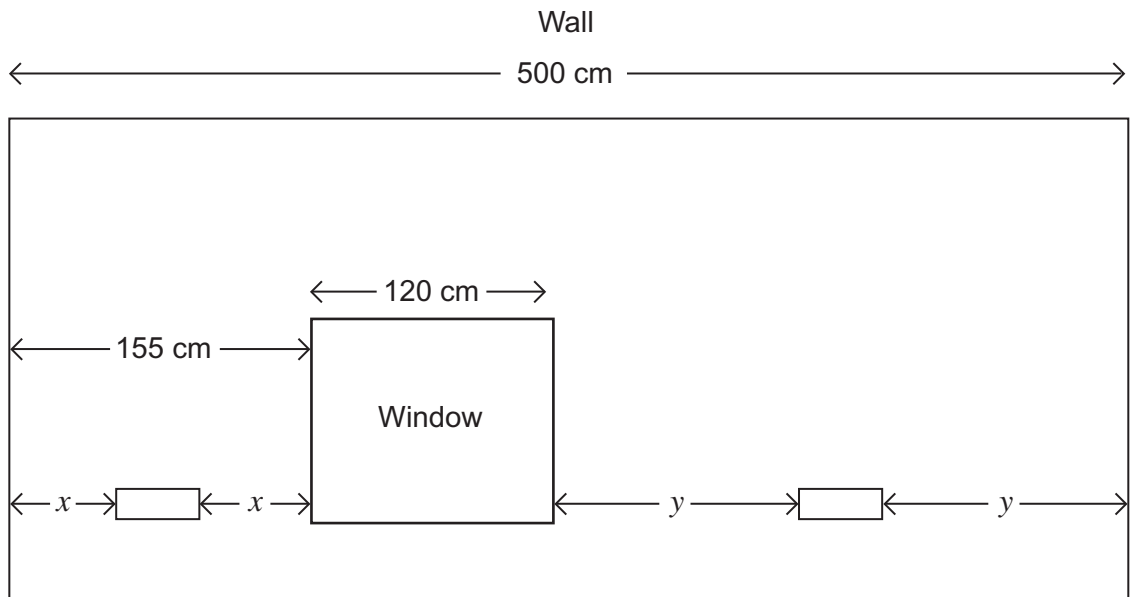

Not drawn accurately

Work out the lengths of  $x$  and  $y$ .

**[5 marks]**

.....

.....

.....

.....

.....

.....

.....

$x =$  ..... cm

$y =$  ..... cm

10

Turn over ►



17 The diagram shows an interior angle of a **regular** polygon.

Not drawn  
accurately

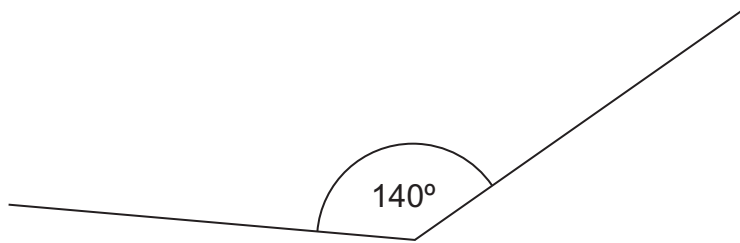

17 (a) Work out the size of an exterior angle of the polygon.

[1 mark]

.....

Answer ..... degrees

17 (b) Work out the number of sides of the polygon.

[2 marks]

.....

.....

.....

Answer .....



18

Not drawn accurately

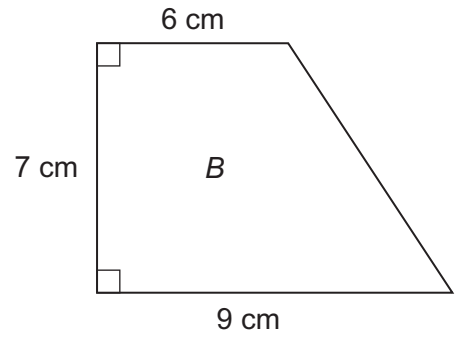
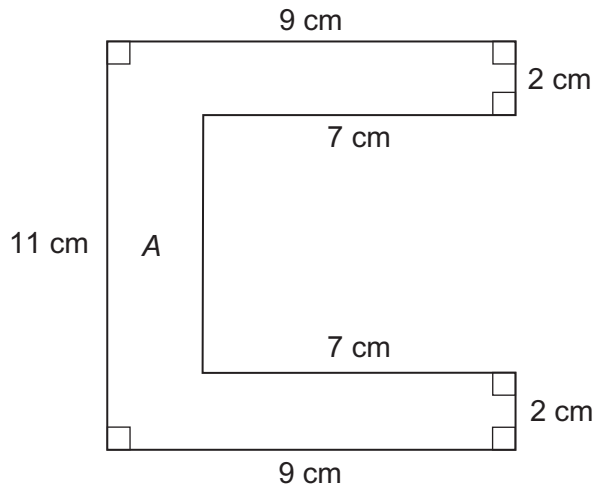

Which shape has the greater **area** and by how much?  
You **must** show your working.

[5 marks]

.....

.....

.....

.....

.....

.....

.....

.....

.....

.....

Shape ..... is greater by ..... cm<sup>2</sup>

8

Turn over ►



**\*19** Use trial and improvement to find the solution to  $x^3 = 6000$

Give your answer to 1 decimal place.

**[4 marks]**

$x$	$x^3$	Comment

$x = \dots\dots\dots$



20

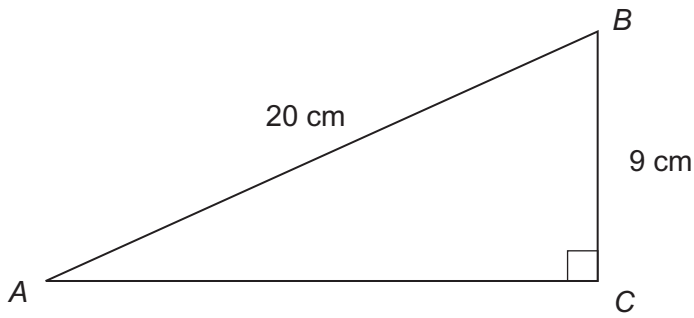

Not drawn  
accurately

Work out the length AC.  
Give your answer to 1 decimal place.

[4 marks]

.....

.....

.....

.....

Answer ..... cm

**END OF QUESTIONS**

8



**There are no questions printed on this page**

**DO NOT WRITE ON THIS PAGE  
ANSWER IN THE SPACES PROVIDED**

