

Write your name here

Surname

Other names

**Pearson**  
**Edexcel GCE**

Centre Number

--	--	--	--	--

Candidate Number

--	--	--	--

# Physics

**Advanced Subsidiary**  
**Unit 2: Physics at Work**

Monday 9 June 2014 – Morning  
**Time: 1 hour 30 minutes**

Paper Reference

**6PH02/01**

**You do not need any other materials.**

Total Marks

## Instructions

- Use **black** ink or ball-point pen.
- **Fill in the boxes** at the top of this page with your name, centre number and candidate number.
- Answer **all** questions.
- Answer the questions in the spaces provided  
– *there may be more space than you need.*

## Information

- The total mark for this paper is 80.
- The marks for **each** question are shown in brackets  
– *use this as a guide as to how much time to spend on each question.*
- Questions labelled with an **asterisk** (\*) are ones where the quality of your written communication will be assessed  
– *you should take particular care with your spelling, punctuation and grammar, as well as the clarity of expression, on these questions.*
- The list of data, formulae and relationships is printed at the end of this booklet.
- Candidates may use a scientific calculator.

## Advice

- Read each question carefully before you start to answer it.
- Keep an eye on the time.
- Try to answer every question.
- Check your answers if you have time at the end.

Turn over ►

P43119A

©2014 Pearson Education Ltd.

1/1/1/



**PEARSON**

## SECTION A

Answer ALL questions.

For questions 1–10, in Section A, select one answer from A to D and put a cross in the box . If you change your mind, put a line through the box  and then mark your new answer with a cross .

1 The distance travelled by a wave during one oscillation may be described as

- A frequency.
- B period.
- C wavelength.
- D wave speed.

(Total for Question 1 = 1 mark)

2 An electric torch uses two 1.5 V cells. The torch bulb is marked 2.4 V, 270 mA.

What is the resistance of the torch bulb?

- A 0.81  $\Omega$
- B 0.65  $\Omega$
- C 8.9  $\Omega$
- D 11  $\Omega$

(Total for Question 2 = 1 mark)

3 All electrical components have resistance.

In which of the following situations would the resistance of the stated component **not** increase?

- A Increasing the current through a filament lamp.
- B Increasing the temperature of a metal wire.
- C Increasing the temperature of a negative temperature coefficient thermistor.
- D Reversing the direction of a diode in forward bias in a circuit.

(Total for Question 3 = 1 mark)



4 Which of the following phenomena does **not** occur with sound waves?

- A diffraction
- B interference
- C polarisation
- D refraction

(Total for Question 4 = 1 mark)

---

5 A lamp illuminates a surface of area  $0.80 \text{ m}^2$  with radiation flux of  $0.50 \text{ W m}^{-2}$ .

The rate, in watts, at which light energy strikes the illuminated surface is given by

- A  $0.50 \times 0.80^2$
- B  $0.50 \times 0.80$
- C  $0.50 \div 0.80$
- D  $0.80 \div 0.50$

(Total for Question 5 = 1 mark)

---



- 6 The diagram represents a resistor of resistance  $R$  in a series circuit with a cell of e.m.f.  $\varepsilon$  and internal resistance  $r$ .

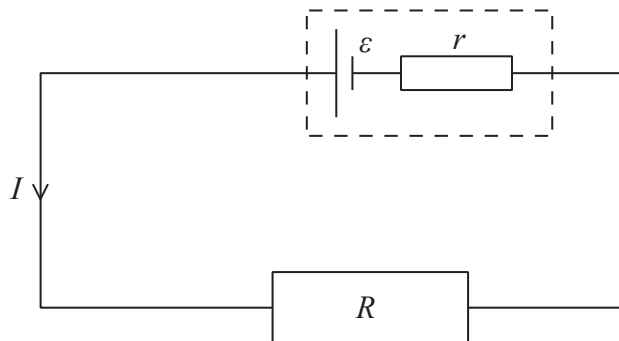

Which of the following correctly gives the potential difference  $V$  across the internal resistance?

- A  $V = \frac{\varepsilon(R+r)}{r}$
- B  $V = \frac{\varepsilon R}{R+r}$
- C  $V = \frac{\varepsilon(R+r)}{R}$
- D  $V = \frac{\varepsilon r}{(R+r)}$

(Total for Question 6 = 1 mark)

- 7 Which of the following is a type of electromagnetic radiation with a wavelength longer than infrared?

- A microwave
- B ultrasound
- C ultraviolet
- D X-rays

(Total for Question 7 = 1 mark)



- 8 A beam of electrons spreads out into several distinct beams after passing through a crystalline material.

This demonstrates that

- A electrons behave as particles.
- B electrons behave as waves.
- C electrons exist in energy levels.
- D electrons have negative charge.

(Total for Question 8 = 1 mark)

- 9 Light in medium 1 strikes a boundary with medium 2 which is also transparent. The diagram shows what happens.

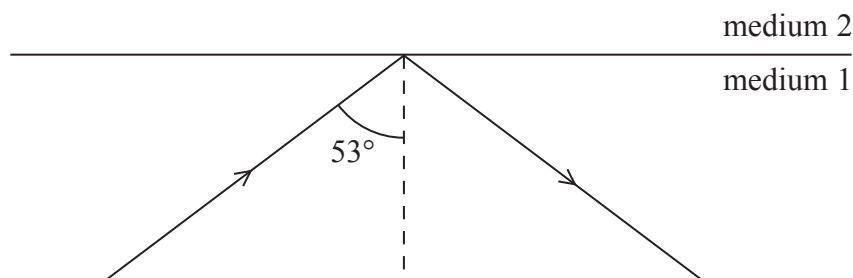

Which of the following can be deduced?

- A The critical angle for light travelling from medium 1 into medium 2 is  $53^\circ$ .
- B The refractive index of medium 1 is greater than the refractive index of medium 2.
- C The speed of light in medium 1 is greater than the speed of light in medium 2.
- D The frequency of light in medium 1 is less than the frequency of light in medium 2.

(Total for Question 9 = 1 mark)

- 10 A rechargeable cell stores a maximum energy of 4200 J. The cell has an e.m.f. of 1.5 V and after 2.0 hours use the cell is completely discharged.

Assuming the e.m.f. stays constant, the charge passing through the cell during this time is

- A 1400 C
- B 2800 C
- C 5600 C
- D 6300 C

(Total for Question 10 = 1 mark)

TOTAL FOR SECTION A = 10 MARKS



**SECTION B**

**Answer ALL questions in the spaces provided.**

- 11** In February 2013 the largest known meteor for a century exploded over the Ural region of Russia.

The explosion was detected by stations monitoring infrasound, a type of sound with a frequency too low for humans to hear.

Describe how infrasound travels through the air.

(3)

.....

.....

.....

.....

.....

.....

.....

.....

.....

.....

**(Total for Question 11 = 3 marks)**

- 12** A student is taking measurements in order to determine the resistance of a component in a circuit. He connects a voltmeter in parallel with the component and an ammeter in series with the component.

Explain why the voltmeter should have a very high resistance.

(2)

.....

.....

.....

.....

.....

.....

.....

.....

.....

.....

**(Total for Question 12 = 2 marks)**



13 (a) Sketch a graph to show how current varies with potential difference for a filament lamp.

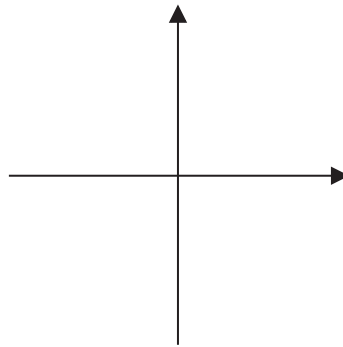

(2)

(b) The temperature of a filament lamp increases as the current through it increases.

Explain this in terms of the structure of a metal.

(3)

.....

.....

.....

.....

.....

.....

.....

.....

.....

.....

**(Total for Question 13 = 5 marks)**



14 Iceland spar is a crystalline form of calcite. An incident ray of unpolarised light is separated into two plane polarised rays by a sample of Iceland spar. The two rays of polarised light follow different paths.

(a) Explain the difference between polarised and unpolarised light.

(3)

.....

.....

.....

.....

.....

.....

.....

.....







15 The graph shows the results for an experiment to demonstrate the photoelectric effect by illuminating a clean metal sheet with light of increasing frequency.

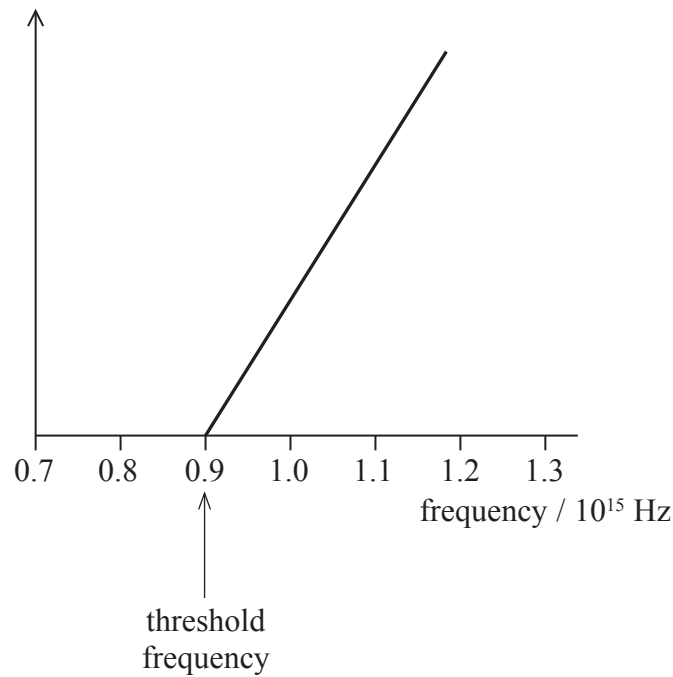

(a) State a quantity, and its unit, which could have been plotted on the Y-axis to produce this graph.

(2)

.....

.....

(b) The threshold frequency is shown on the graph.

Explain why there is a threshold frequency.

(4)

.....

.....

.....

.....

.....

.....

.....

.....

.....

.....

(Total for Question 15 = 6 marks)



16 An electric kettle is used to heat water from room temperature to boiling point.

(a) (i) Calculate the electrical power used by the kettle.

potential difference = 230 V

current = 12.5 A

(2)

Electrical power = .....

(ii) The kettle is switched on for 140 s.

Calculate the total energy supplied to the kettle.

(2)

Total energy supplied = .....

(iii) The amount of thermal energy transferred to the water is calculated to be 351 000 J.

Calculate the efficiency of the kettle at heating the water.

(2)

Efficiency = .....

(b) A student suggests that the useful energy required is thermal and the kettle only produces thermal energy, so it should be 100 % efficient.

Discuss this suggestion.

(2)

(Total for Question 16 = 8 marks)





- (c) An electron in level  $E_3$  of neon has 0.05 eV more energy than an electron in level  $E_2$  of helium.

Suggest the source of the energy to make up this difference.

(1)

- (d) The photograph shows a device for making a vertical slit with variable width.



© THORLABS, Inc.

When the slit is fully open a laser beam is shone through it and a single point of light is seen on a screen.

As the slit is reduced in width the point of light becomes a horizontal line that gets longer as the slit gets narrower.

Explain this observation.

(3)

(Total for Question 17 = 9 marks)



18 Photograph 1 shows a rheostat (a variable resistor).

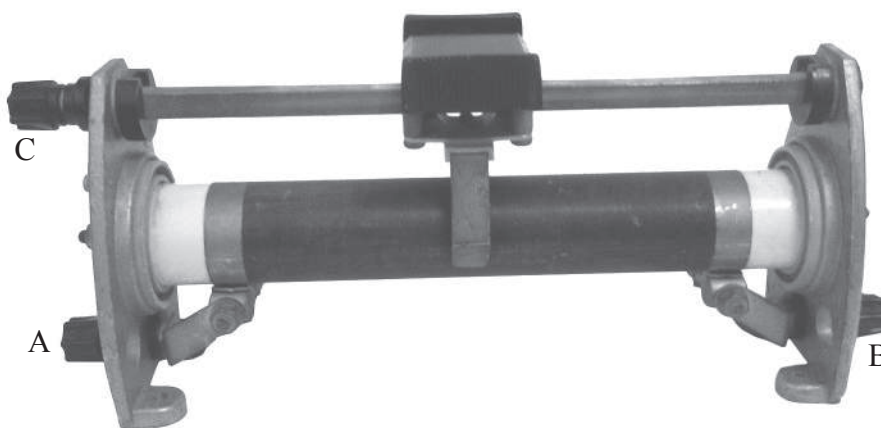

**Photograph 1**

The rheostat is made of a long resistance wire coiled around an insulating cylinder. The turns of wire are also separated from each other by insulation of negligible thickness. The ends of the wire are connected to the sockets A and B at either end and there is a sliding contact in the centre connected to the socket C. The resistance between A and C is varied by moving the sliding contact.

- (a) A student decides to determine the resistivity of the material from which the wire is made by measuring the dimensions of the wire and its resistance.

Photograph 2 shows a section of the rheostat and a scale.

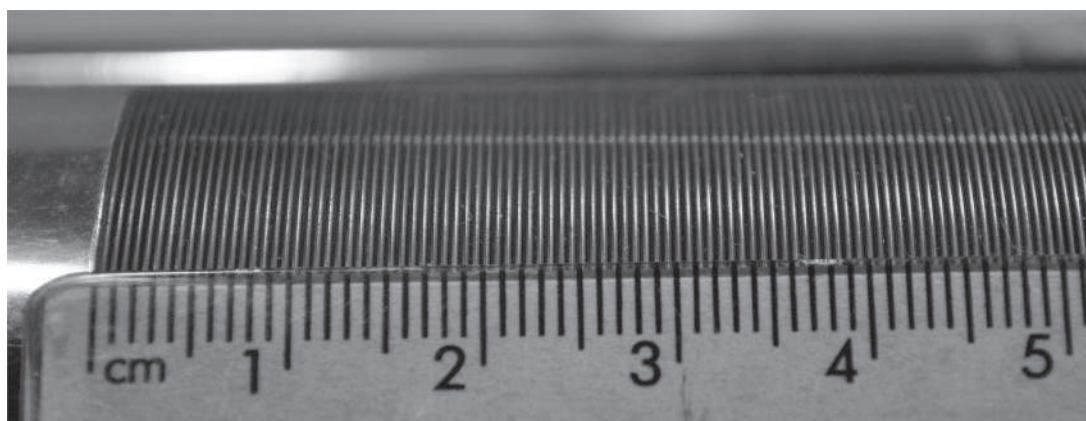

**Photograph 2**

- (i) Take measurements from the photograph and use them to show that the cross-sectional area of the wire is about  $2 \times 10^{-7} \text{ m}^2$ .

(3)

.....

.....

.....

.....



(ii) Calculate the resistivity of the material from which the wire is made.

resistance of wire =  $22 \Omega$

length of wire = 12 m

(3)

Resistivity = .....

(iii) Suggest an advantage for the student of using a photograph rather than taking direct measurements.

(1)

(b) The coil of the rheostat is 10.2 cm long. A potential difference of 12 V is applied across AB and the slider C is 7.0 cm from the end of the coil near A.

Calculate the potential difference across AC.

(2)

Potential difference = .....

**(Total for Question 18 = 9 marks)**







(b) (i) Explain why pulses of microwaves are used rather than a continuous beam. (1)

.....

.....

(ii) Calculate the maximum pulse duration which would enable distances between 5 km and 200 km to be measured. (3)

.....

.....

.....

Maximum pulse duration = .....

**(Total for Question 19 = 10 marks)**



**BLANK PAGE**



- 20 A book entitled *Interesting Projects with a Microwave Oven* suggests using chocolate to measure the speed of light. The chocolate is placed on a non-metallic tray in the oven. The oven is switched on and a pattern is observed in the melting chocolate.



The photograph shows some lighter areas where the chocolate is melting and some darker areas where the chocolate remains hard.

The book states that microwaves are emitted from the source in the oven. The microwaves reflect off the metal walls so that the microwaves reaching any point arrive from different directions. The microwaves produce a standing wave pattern causing hot and cold areas in the oven.

The wavelength was determined to be 12 cm by measuring the distance between adjacent hot and cold areas.



(a) The diagram shows two different paths by which microwaves can reach the point Z.

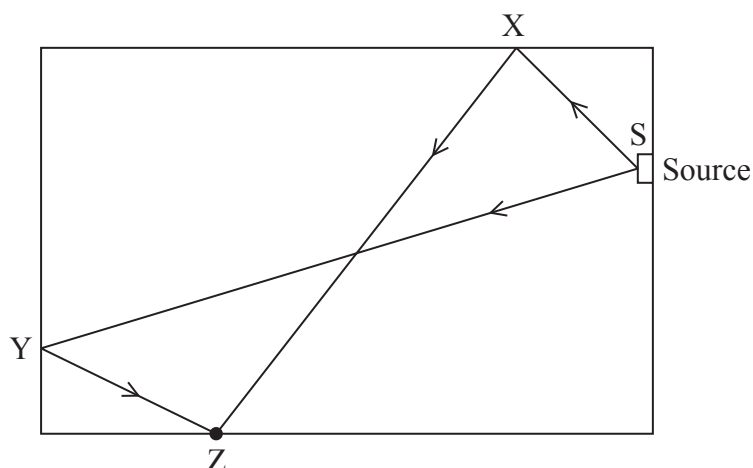

Not to scale

$SX = 9 \text{ cm}$ ,  $XZ = 23 \text{ cm}$ ,  $SY = 36 \text{ cm}$ ,  $YZ = 8 \text{ cm}$

Calculate the phase difference between microwaves from the source at S reaching point Z by the two different paths.

(2)

.....

.....

.....

Phase difference = .....

(b) Explain how a pattern of hot and cold areas is produced in the chocolate. You should assume that each point of the chocolate is reached by microwaves following two different paths only.

(4)

.....

.....

.....

.....

.....

.....

.....

.....

.....

.....



(c) Explain why the microwaves reaching a point in the chocolate must be coherent for this effect to occur.

(2)

.....

.....

.....

.....

(d) The microwave frequency is stated on the oven as 2450 MHz.

Evaluate the success of this experiment at determining the speed of light.

(3)

.....

.....

.....

.....

.....

.....

.....

.....

---

**(Total for Question 20 = 11 marks)**

---

---

**TOTAL FOR SECTION B = 70 MARKS**

**TOTAL FOR PAPER = 80 MARKS**



## List of data, formulae and relationships

Acceleration of free fall	$g = 9.81 \text{ m s}^{-2}$	(close to Earth's surface)
Electron charge	$e = -1.60 \times 10^{-19} \text{ C}$	
Electron mass	$m_e = 9.11 \times 10^{-31} \text{ kg}$	
Electronvolt	$1 \text{ eV} = 1.60 \times 10^{-19} \text{ J}$	
Gravitational field strength	$g = 9.81 \text{ N kg}^{-1}$	(close to Earth's surface)
Planck constant	$h = 6.63 \times 10^{-34} \text{ J s}$	
Speed of light in a vacuum	$c = 3.00 \times 10^8 \text{ m s}^{-1}$	

### Unit 1

#### Mechanics

Kinematic equations of motion	$v = u + at$ $s = ut + \frac{1}{2}at^2$ $v^2 = u^2 + 2as$
-------------------------------	---

Forces	$\Sigma F = ma$ $g = F/m$ $W = mg$
--------	------------------------------------

Work and energy	$\Delta W = F\Delta s$ $E_k = \frac{1}{2}mv^2$ $\Delta E_{\text{grav}} = mg\Delta h$
-----------------	--

#### Materials

Stokes' law	$F = 6\pi\eta rv$
-------------	-------------------

Hooke's law	$F = k\Delta x$
-------------	-----------------

Density	$\rho = m/V$
---------	--------------

Pressure	$p = F/A$
----------	-----------

Young modulus	$E = \sigma/\varepsilon$ where Stress $\sigma = F/A$ Strain $\varepsilon = \Delta x/x$
---------------	--

Elastic strain energy	$E_{\text{el}} = \frac{1}{2}F\Delta x$
-----------------------	--



## Unit 2

### Waves

Wave speed  $v = f\lambda$

Refractive index  ${}_1\mu_2 = \sin i / \sin r = v_1 / v_2$

### Electricity

Potential difference  $V = W/Q$

Resistance  $R = V/I$

Electrical power, energy and efficiency  
 $P = VI$   
 $P = I^2R$   
 $P = V^2/R$   
 $W = VI t$

$$\% \text{ efficiency} = \frac{\text{useful energy output}}{\text{total energy input}} \times 100$$

$$\% \text{ efficiency} = \frac{\text{useful power output}}{\text{total power input}} \times 100$$

Resistivity  $R = \rho l/A$

Current  
 $I = \Delta Q / \Delta t$   
 $I = nqvA$

Resistors in series  $R = R_1 + R_2 + R_3$

Resistors in parallel  
 $\frac{1}{R} = \frac{1}{R_1} + \frac{1}{R_2} + \frac{1}{R_3}$

### Quantum physics

Photon model  $E = hf$

Einstein's photoelectric equation  
 $hf = \phi + \frac{1}{2}mv_{\max}^2$



**BLANK PAGE**

