

Write your name here	
Surname	Other names
Centre Number	Candidate Number
<input type="text"/>	<input type="text"/>
Edexcel GCE	
Physics	
Advanced Subsidiary	
Unit 1: Physics on the Go	
Tuesday 24 May 2011 – Morning Time: 1 hour 30 minutes	Paper Reference 6PH01/01
You must have: Ruler	Total Marks

Instructions

- Use **black** ink or ball-point pen.
- **Fill in the boxes** at the top of this page with your name, centre number and candidate number.
- Answer **all** questions.
- Answer the questions in the spaces provided
– *there may be more space than you need.*

Information

- The total mark for this paper is 80.
- The marks for **each** question are shown in brackets
– *use this as a guide as to how much time to spend on each question.*
- Questions labelled with an **asterisk** (*) are ones where the quality of your written communication will be assessed
– *you should take particular care with your spelling, punctuation and grammar, as well as the clarity of expression, on these questions.*
- The list of data, formulae and relationships is printed at the end of this booklet.
- Candidates may use a scientific calculator.

Advice

- Read each question carefully before you start to answer it.
- Keep an eye on the time.
- Try to answer every question.
- Check your answers if you have time at the end.

Turn over ►

P38414A

©2011 Edexcel Limited.
1/1/1/1



edexcel 
advancing learning, changing lives

SECTION A

Answer ALL questions.

For questions 1–10, in Section A, select one answer from A to D and put a cross in the box .
If you change your mind, put a line through the box and then
mark your new answer with a cross .

1 Which of the following is **not** a vector quantity?

- A displacement
- B force
- C weight
- D work

(Total for Question 1 = 1 mark)

2 Which of the following units is equivalent to the SI unit for energy?

- A kg m s^{-2}
- B kW h
- C N m^{-1}
- D W s

(Total for Question 2 = 1 mark)



3 The graph shows how tensile stress varies with tensile strain for a wire.

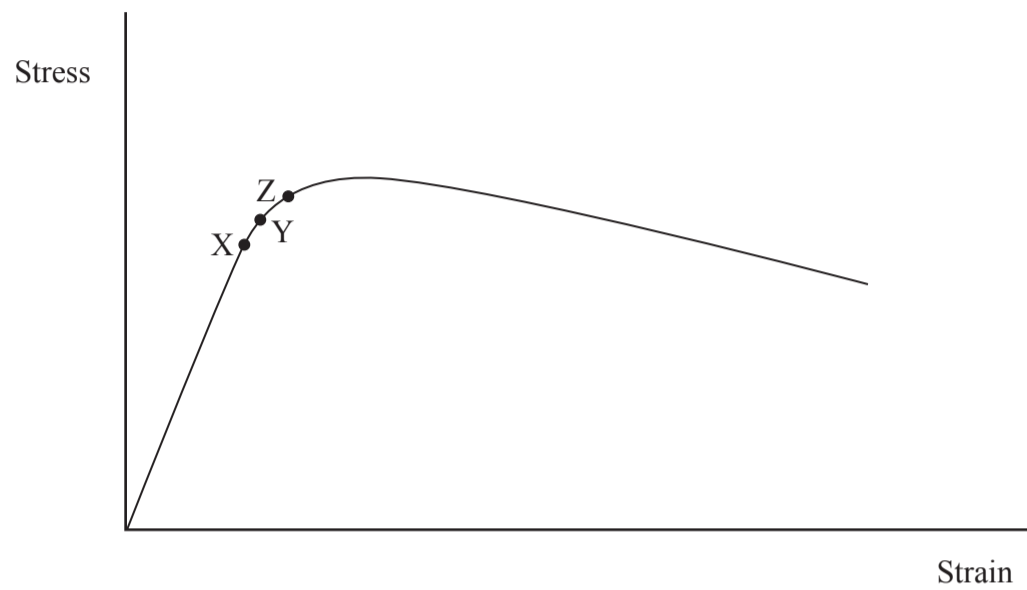

Which row of the table could give the correct terms for points X, Y and Z?

		X	Y	Z
<input type="checkbox"/>	A	Elastic limit	Yield point	Maximum tensile stress
<input type="checkbox"/>	B	Limit of proportionality	Elastic limit	Yield point
<input type="checkbox"/>	C	Elastic limit	Maximum tensile stress	Limit of proportionality
<input type="checkbox"/>	D	Limit of proportionality	Yield point	Maximum tensile stress

(Total for Question 3 = 1 mark)

4 The acceleration of free fall on Mars is 3.7 m s^{-2} .

If an object on Mars is launched vertically upwards with an initial speed of 40 m s^{-1} , its speed after 3.0 s will be

- A** 11 m s^{-1}
- B** 29 m s^{-1}
- C** 36 m s^{-1}
- D** 51 m s^{-1}

(Total for Question 4 = 1 mark)



5 The gravitational field strength on Mars is 3.7 N kg^{-1} .

A 5.0 kg object is raised through a height of 150 cm on Mars. The change in gravitational potential energy is

- A 19 J
- B 28 J
- C 49 J
- D 74 J

(Total for Question 5 = 1 mark)

6 A ball is dropped to the ground and caught when it bounces up again.

Which of the following graphs shows the velocity of the ball?

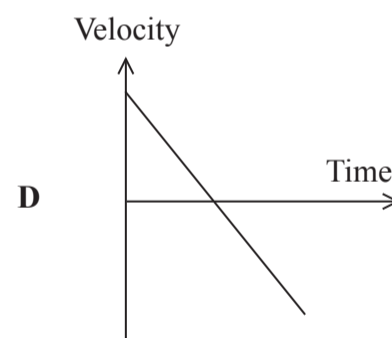
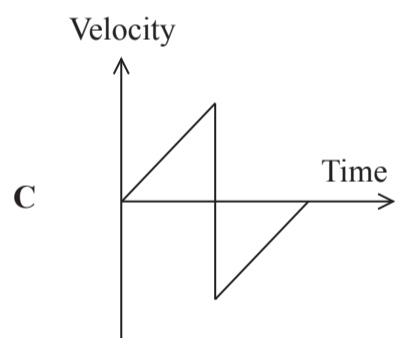
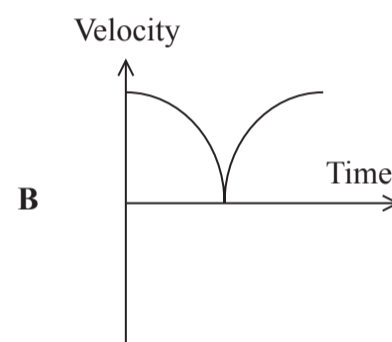
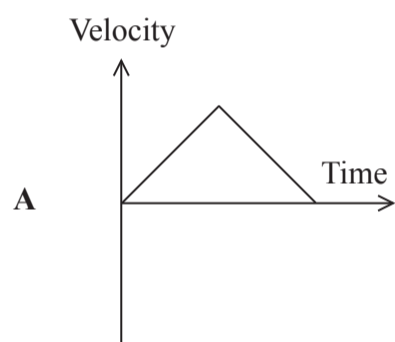

- A
- B
- C
- D

(Total for Question 6 = 1 mark)



7 A material which resists plastic deformation by scratching is described as

- A brittle
- B hard
- C malleable
- D stiff

(Total for Question 7 = 1 mark)

8 A child goes down a slide. Which of the diagrams correctly represents the forces acting on the child?

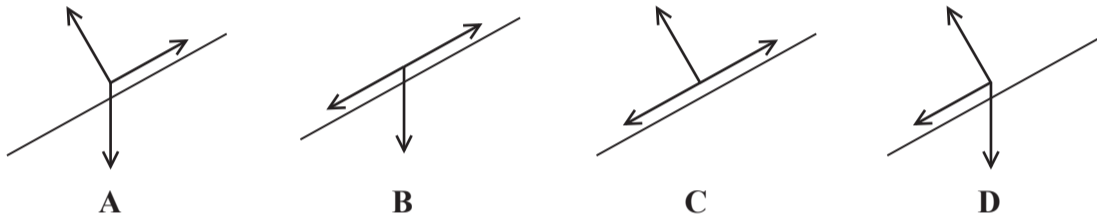

- A
- B
- C
- D

(Total for Question 8 = 1 mark)

9 The gradient of a displacement-time graph gives

- A acceleration
- B displacement
- C force
- D velocity

(Total for Question 9 = 1 mark)



10 A table tennis ball is released beneath the surface of water and moves upwards.

The relationship between the forces acting on the ball when it reaches terminal velocity is

- A** weight = upthrust
- B** weight + drag = upthrust
- C** weight = upthrust + drag
- D** weight = drag

(Total for Question 10 = 1 mark)

TOTAL FOR SECTION A = 10 MARKS



SECTION B

Answer ALL questions in the spaces provided.

11 (a) What is meant by a vector quantity?

(1)

.....
.....

(b) A car is driven around a bend at a constant speed.

Explain what happens to its velocity.

(2)

.....
.....
.....
.....
.....

(Total for Question 11 = 3 marks)



12 The photograph shows someone using a vacuum cleaner.



- (a) A force of 38 N is applied at an angle of 60° to the horizontal. The vacuum cleaner moves across the floor at a constant speed.

Calculate the magnitude of the horizontal resistive force acting on the vacuum cleaner.

(2)

.....

.....

.....

Resistive force =

- (b) The room is 5.5 m long. The vacuum cleaner is pushed 20 times across the room to clean the carpet.

Calculate the work done against the horizontal resistive force.

(2)

.....

.....

.....

Work done =



(c) Each 5.5 m length takes a time of 9.0 s.

Calculate the rate at which this work is done.

(2)

Rate of work done =

(Total for Question 12 = 6 marks)

13 A student is required to measure the speed of a trolley rolling down a slope. This could be done using a ruler and stopwatch but the student prefers a method using ICT.

(a) The student uses a light gate as shown in the diagram.

Describe how the student obtains the measurements needed to calculate speed.

(2)

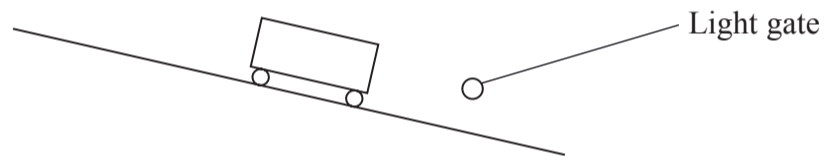

(b) The student thinks that the stopwatch method is less reliable than the ICT method.

Discuss what makes using a stopwatch less reliable.

(2)

(Total for Question 13 = 4 marks)



14 The diagram shows a crane lifting a concrete beam.

mass of beam = 1300 kg
diameter of steel cable = 1.1 cm

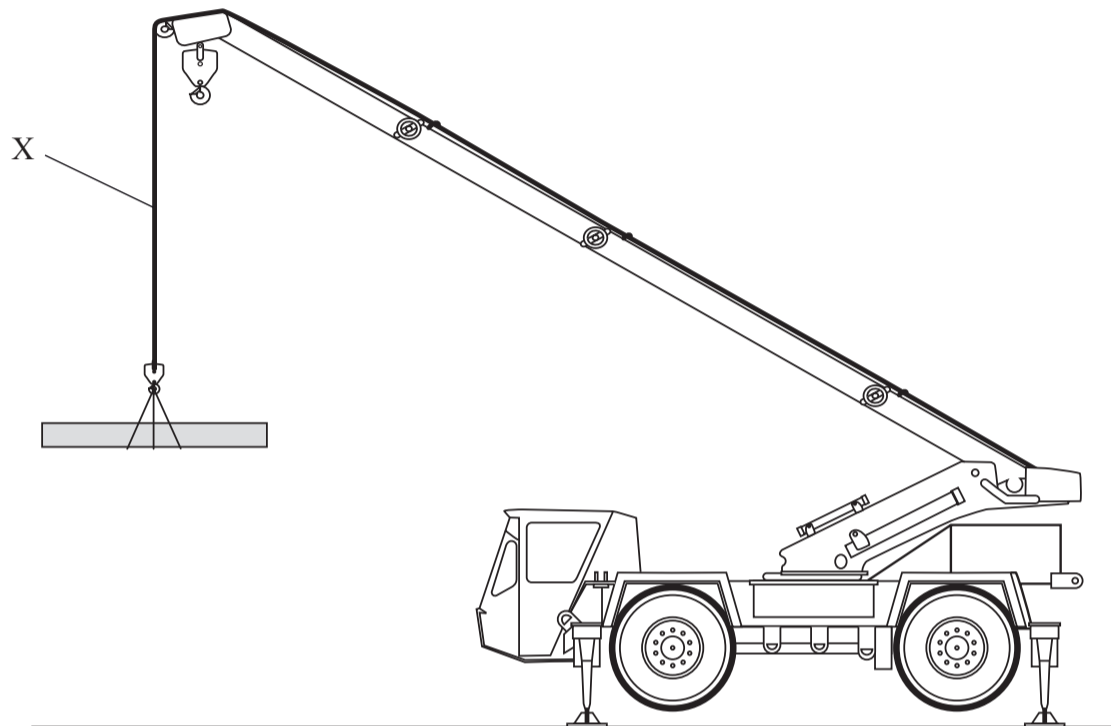

(a) Show that the stress in the cable at point X is about 0.1 GPa.

(4)

.....

.....

.....

.....

.....



(b) The original length of the cable with no load is 15 m.

Calculate its extension when lifting the beam.

Young modulus for steel = 195 GPa

(3)

.....

.....

.....

.....

.....

.....

Extension =

(c) The steel cable consists of six strands each made of thirty seven wires.

Suggest why this is preferred to a single piece of steel.

(1)

.....

.....

.....

(Total for Question 14 = 8 marks)



(c) Explain **one** experimental precaution you would take to ensure you obtain accurate results.

(2)

.....

.....

.....

.....

(Total for Question 15 = 11 marks)



16 The photograph shows a solar-powered model boat built by some technology students.

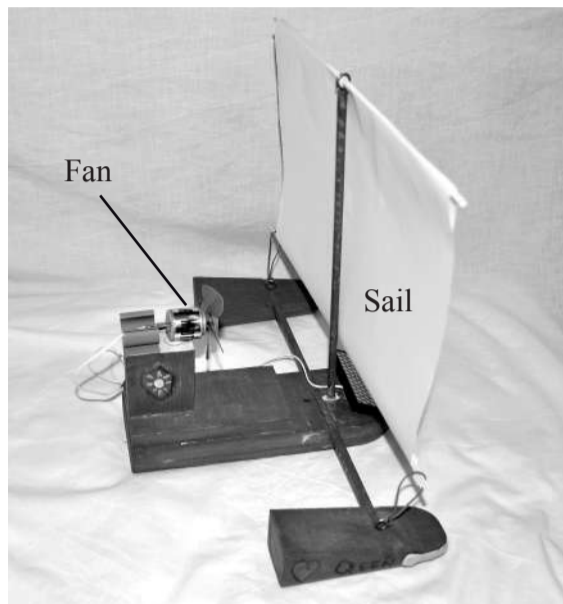

This boat has a solar-powered fan attached. The fan blows air towards the sail.

(a) The technology students explain to a physics student that the fan exerts a force on the air and the air then exerts an equal force on the sail to drive the boat forwards. Assume that these two forces are equal for the rest of the question. The physics student tells them that according to Newton's laws of motion this will not work.

(i) Identify the Newton's third law force that pairs with the force of the fan on the air.

(1)

(ii) The boat is placed in the water and the fan switched on. The boat remains at rest. Add labelled arrows to the diagram below to show the **four** forces acting on the boat in this situation.

(2)

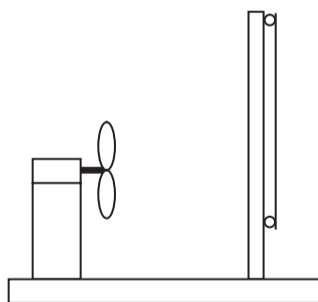

*(iii) Use Newton's laws of motion to explain why the boat does not move horizontally.

(3)

.....

.....

.....

.....

.....

(b) The physics student suggests that the boat is more likely to work if the fan is reversed to point in the opposite direction.

Explain this suggestion.

(2)

.....

.....

.....

(c) Calculate the volume of water, in m^3 , which must be displaced so that the boat will float.

mass of boat = 130 g
density of water = 1000 kg m^{-3}

(2)

.....

.....

.....

Volume =

(Total for Question 16 = 10 marks)



BLANK PAGE



17 A student carries out an experiment in which a column of liquid glycerol flows through a narrow glass tube. The time taken for the top of the glycerol column to fall a known distance between two markers is measured with a stopwatch. The experiment is repeated at different temperatures.

The student records the following results.

Temperature / °C	Time taken / s	Average speed / m s ⁻¹
26.5	4.2	0.019
35.5	2.4	0.033
42.5	1.5	
50.0	1.2	0.067
61.5	0.5	0.160

- (a) (i) The table shows the average speed of flow for four of the temperatures. Calculate the missing value and enter it in the table. The distance between the markers is 0.080 m.

(1)

- (ii) Add this point to the graph below and draw a best-fit line for the student's data.

(2)

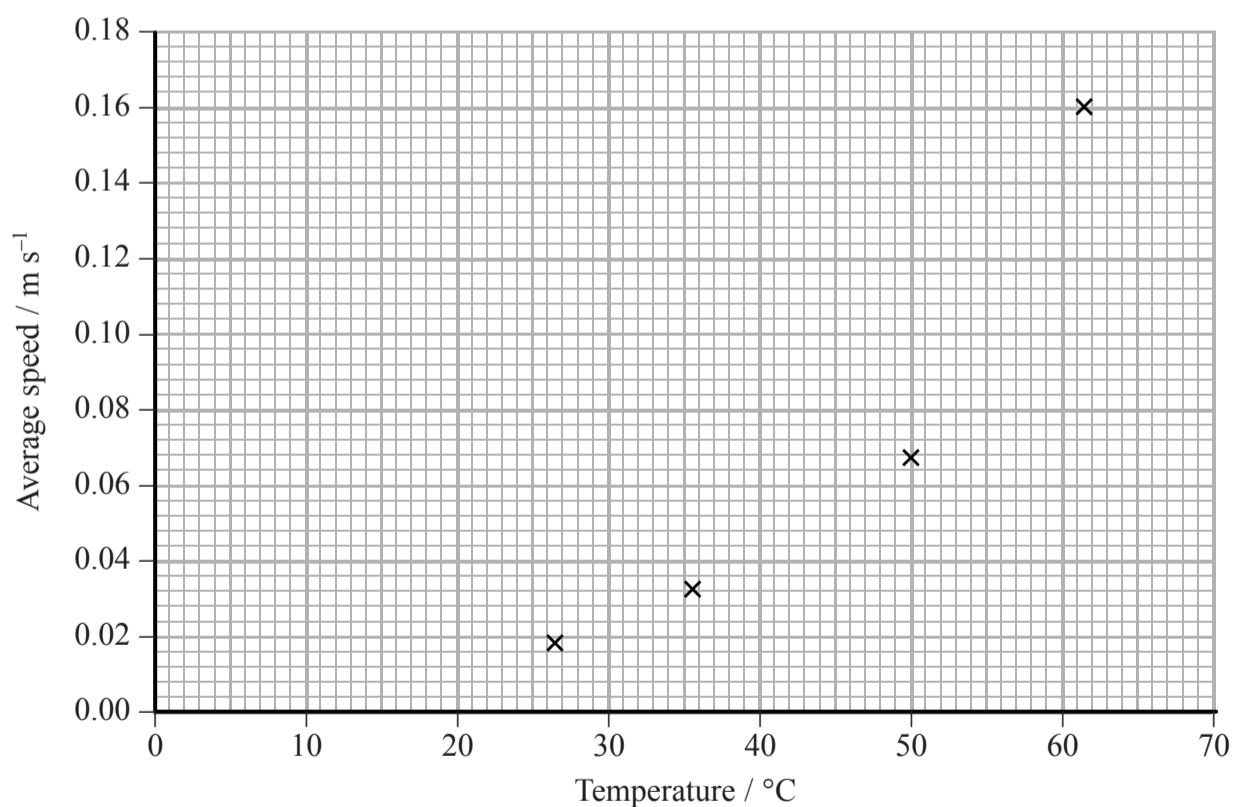

(iii) Use these results to explain how the viscosity of glycerol varies with temperature.

(2)

.....

.....

.....

.....

(b) This experiment depends on the flow remaining laminar and not becoming turbulent.

(i) Explain these **two** terms and complete the diagrams to illustrate each type of flow through a vertical tube.

(4)

laminar

.....

.....



turbulent

.....

.....



(ii) Explain the effect turbulence would have on the rate of flow.

(2)

.....

.....

.....



(c) The student thinks that the value measured for 61.5 °C is the most likely point to be incorrect based on the technique described at the start of the question.

Explain why this should be so.

(2)

.....

.....

.....

.....

(Total for Question 17 = 13 marks)



18 The photograph shows a flygun.



The flygun consists of a handle, a spring and a disc as shown in the photograph below.

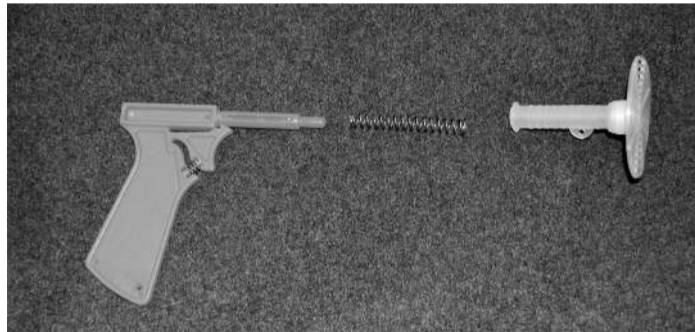

When the trigger is pulled, the compressed spring is released, launching the disc at the fly.



A force-compression graph for the spring is shown.

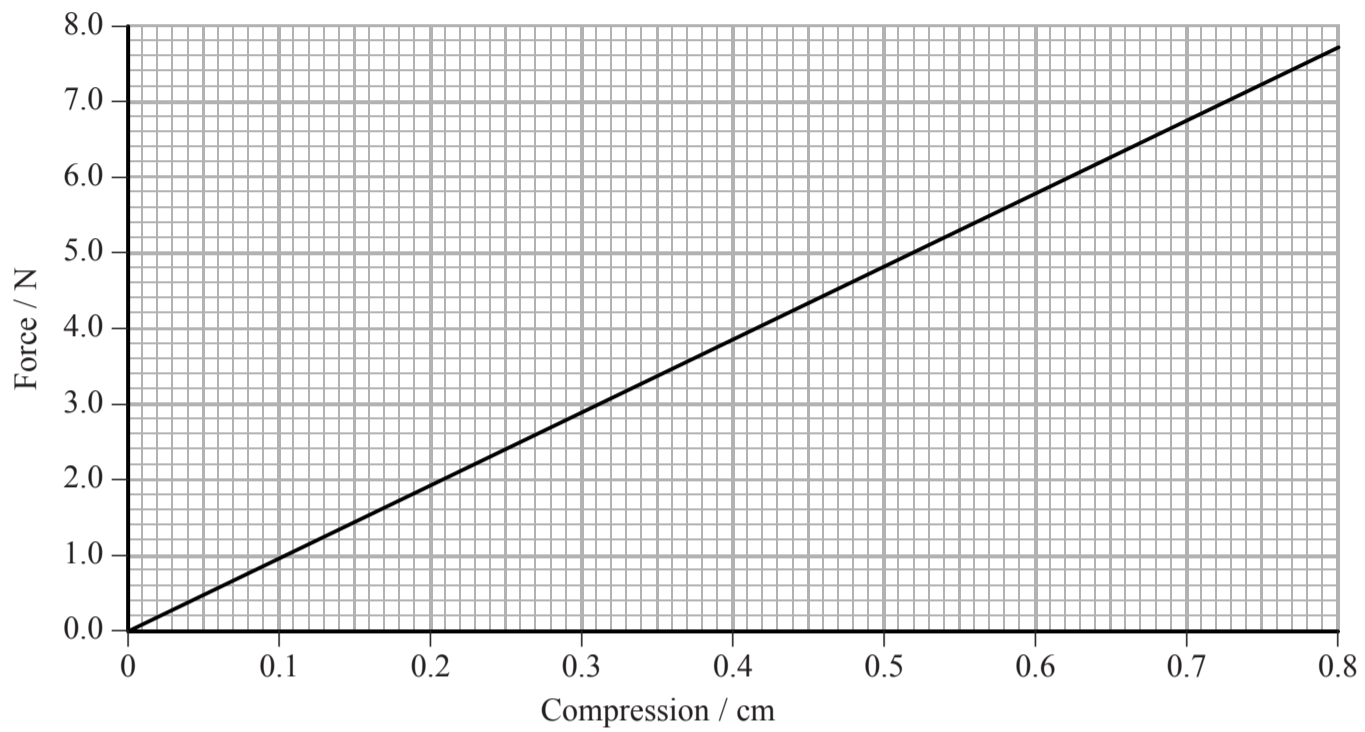

(a) Show that the force constant for the spring is about 1000 N m^{-1} .

(2)

.....

.....

.....

.....

(b) The spring is 6.3 cm long. When it is compressed in the gun, the length of the spring is reduced to 1.6 cm.

Assuming that the spring obeys Hooke's law throughout the compression, show that the energy stored in the spring before firing the gun is about 1 J.

(2)

.....

.....

.....

.....



(c) The disc and spring have a combined mass of 9.4 g.

(i) Show that the maximum speed at which they can be fired is about 15 m s^{-1} .

(2)

.....

.....

.....

(ii) State an assumption that you have made.

(1)

.....

.....

(d) The gun is fired at a fly on a wall 3.0 m away. The gun is fired horizontally.

(i) Calculate the velocity of the disc as it hits the wall. Ignore the effects of air resistance.

(4)

.....

.....

.....

.....

.....

.....

.....

.....

.....

.....

Magnitude of velocity =

Angle to the horizontal =



(ii) The fly is 20 cm below the horizontal level at which the gun is fired. Show that the disc is close enough to hit the fly if it does not move. The disc has a radius of 3 cm.

(3)

.....

.....

.....

.....

.....

.....

.....

.....

.....

.....

.....

(e) Suggest an advantage of the disc used over a solid disc.

(1)

.....

.....

.....

.....

(Total for Question 18 = 15 marks)

TOTAL FOR SECTION B = 70 MARKS

TOTAL FOR PAPER = 80 MARKS



List of data, formulae and relationships

Acceleration of free fall	$g = 9.81 \text{ m s}^{-2}$	(close to Earth's surface)
Electron charge	$e = -1.60 \times 10^{-19} \text{ C}$	
Electron mass	$m_e = 9.11 \times 10^{-31} \text{ kg}$	
Electronvolt	$1 \text{ eV} = 1.60 \times 10^{-19} \text{ J}$	
Gravitational field strength	$g = 9.81 \text{ N kg}^{-1}$	(close to Earth's surface)
Planck constant	$h = 6.63 \times 10^{-34} \text{ J s}$	
Speed of light in a vacuum	$c = 3.00 \times 10^8 \text{ m s}^{-1}$	

Unit 1

Mechanics

Kinematic equations of motion	$v = u + at$ $s = ut + \frac{1}{2}at^2$ $v^2 = u^2 + 2as$
Forces	$\Sigma F = ma$ $g = F/m$ $W = mg$
Work and energy	$\Delta W = F\Delta s$ $E_k = \frac{1}{2}mv^2$ $\Delta E_{\text{grav}} = mg\Delta h$

Materials

Stokes' law	$F = 6\pi\eta rv$
Hooke's law	$F = k\Delta x$
Density	$\rho = m/V$
Pressure	$p = F/A$
Young modulus	$E = \sigma/\epsilon$ where Stress $\sigma = F/A$ Strain $\epsilon = \Delta x/x$
Elastic strain energy	$E_{\text{el}} = \frac{1}{2}F\Delta x$

