

Write your name here	
Surname	Other names
Centre Number	Candidate Number
<input type="text"/>	<input type="text"/>
Edexcel GCE	
Physics	
Advanced Subsidiary	
Unit 1: Physics on the Go	
Thursday 27 May 2010 – Afternoon Time: 1 hour 30 minutes	Paper Reference 6PH01/01
You must have: Ruler	Total Marks

Instructions

- Use **black** ink or ball-point pen.
- **Fill in the boxes** at the top of this page with your name, centre number and candidate number.
- Answer **all** questions.
- Answer the questions in the spaces provided
– *there may be more space than you need.*

Information

- The total mark for this paper is 80.
- The marks for **each** question are shown in brackets
– *use this as a guide as to how much time to spend on each question.*
- Questions labelled with an **asterisk** (*) are ones where the quality of your written communication will be assessed
– *you should take particular care with your spelling, punctuation and grammar, as well as the clarity of expression, on these questions.*
- The list of data, formulae and relationships is printed at the end of this booklet.
- Candidates may use a scientific calculator.

Advice

- Read each question carefully before you start to answer it.
- Keep an eye on the time.
- Try to answer every question.
- Check your answers if you have time at the end.

Turn over ►

N35875A

©2010 Edexcel Limited.

1/1/1/1/



edexcel 
advancing learning, changing lives

SECTION A

Answer ALL questions.

For questions 1–10, in Section A, select one answer from A to D and put a cross in the box .
If you change your mind, put a line through the box and then
mark your new answer with a cross .

1 Distance travelled can be found from the

- A** area under a velocity-time graph
- B** area under an acceleration-time graph
- C** gradient of a force-time graph
- D** gradient of a velocity-time graph

(Total for Question 1 = 1 mark)

2 Which of the following is a scalar quantity?

- A** acceleration
- B** displacement
- C** force
- D** work

(Total for Question 2 = 1 mark)

3 A car pulls a trailer of weight 2500 N with a force of 20 N for a distance of 8 km along a horizontal road.

How much work is done by the car in pulling the trailer?

- A** 160 J
- B** 20 000 J
- C** 160 000 J
- D** 20 000 000 J

(Total for Question 3 = 1 mark)



4 A person is standing at point C in a train carriage travelling round a sharp bend to the right. The person jumps up. Nearest which marked point is the person most likely to land?

Direction of bend

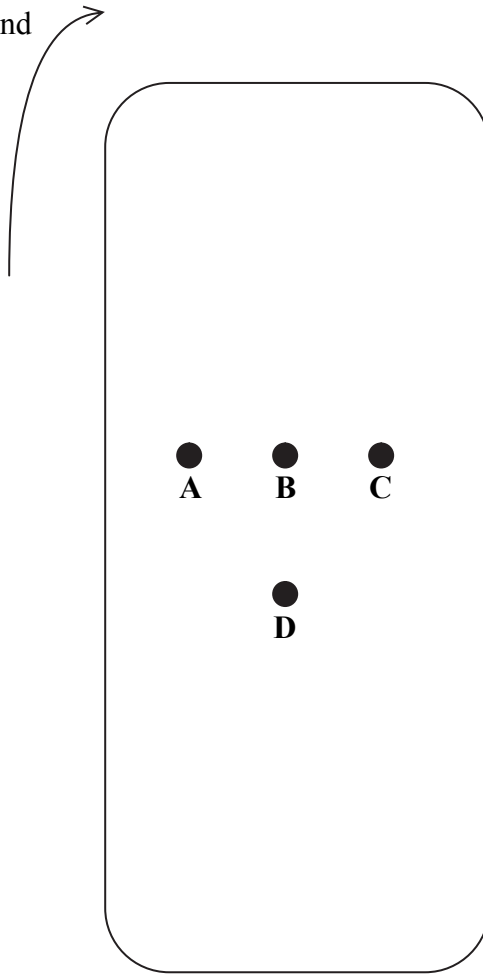

- A
- B
- C
- D

(Total for Question 4 = 1 mark)



5 Which of the following units could be used for power?

- A kg m s^{-2}
- B $\text{kg m}^2 \text{s}^{-2}$
- C $\text{kg m}^2 \text{s}^{-3}$
- D $\text{kg}^2 \text{m}^2 \text{s}^{-3}$

(Total for Question 5 = 1 mark)

6 A ball is thrown straight up in the air and caught when it comes down. Which graph best shows the velocity of the ball from the moment it is released until just before it is caught?

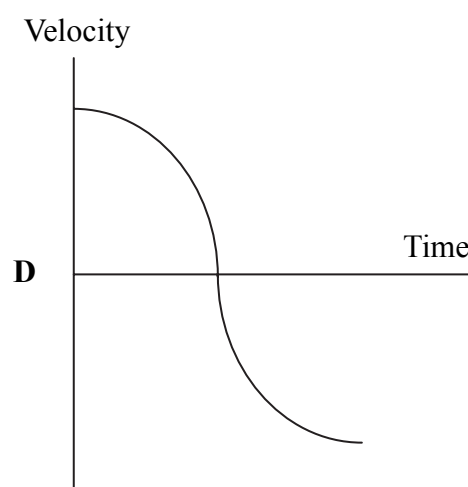
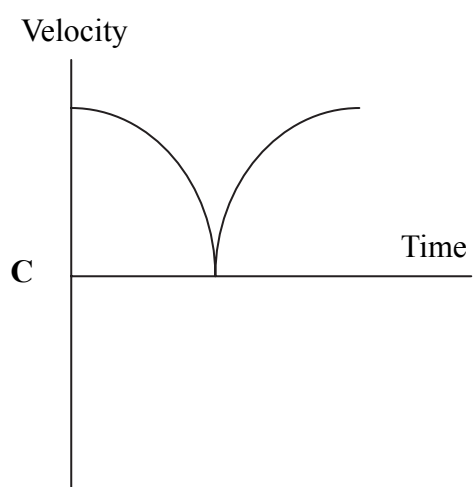
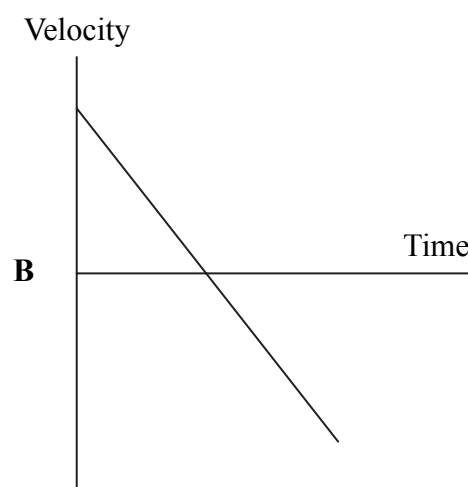
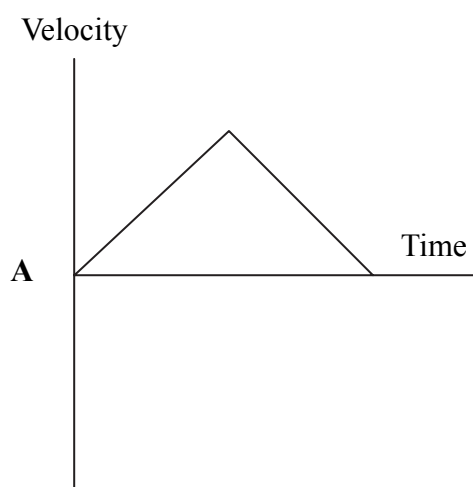

- A
- B
- C
- D

(Total for Question 6 = 1 mark)



7 A building has 5 floors. The windows on successive floors are separated by the same vertical distance. A brick is dropped from a window on each floor at the same time. The bricks should hit the ground at

- A decreasing time intervals
- B equal time intervals
- C increasing time intervals
- D the same time

(Total for Question 7 = 1 mark)

8 All ductile materials are also

- A brittle
- B hard
- C malleable
- D stiff

(Total for Question 8 = 1 mark)



Use the diagram below for questions 9 and 10.

The diagram shows four forces acting on an aeroplane.

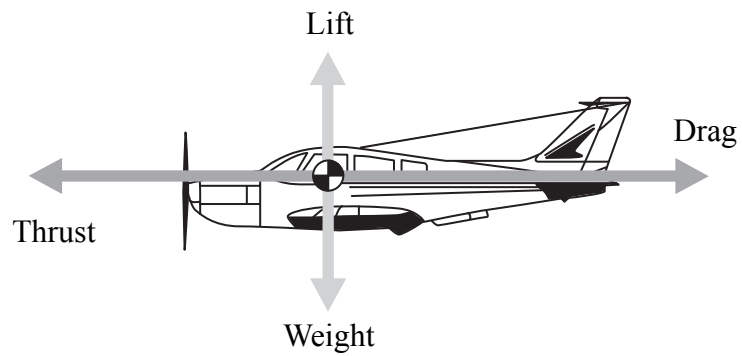

9 Which of the following shows the correct two relationships if the aeroplane is climbing at a constant velocity?

		Relationship 1	Relationship 2
<input type="checkbox"/>	A	lift > weight	thrust > drag
<input type="checkbox"/>	B	lift > weight	thrust = drag
<input type="checkbox"/>	C	lift = weight	thrust > drag
<input type="checkbox"/>	D	lift = weight	thrust = drag

(Total for Question 9 = 1 mark)

10 The aeroplane is now flown at a constant altitude but an increasing speed.

Which of the following pairs of forces will have the same magnitude?

- A** drag and weight
- B** drag and thrust
- C** lift and drag
- D** lift and weight

(Total for Question 10 = 1 mark)

TOTAL FOR SECTION A = 10 MARKS



SECTION B

Answer ALL questions in the spaces provided.

11 The diagram shows part of the upper surface of an aeroplane wing.

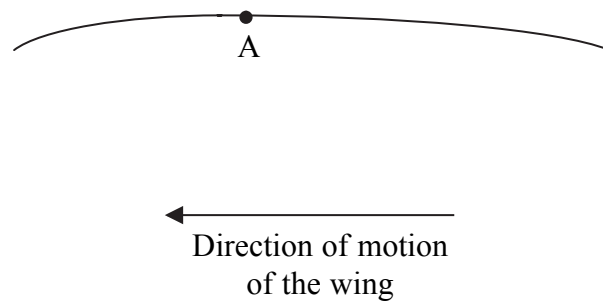

At point A the air flow changes from laminar to turbulent.

Complete the diagram to show the airflow before and after point A.

(Total for Question 11 = 2 marks)



***12** Explain the difference between elastic deformation and plastic deformation. Use the behaviour of the same material or object to illustrate both types of deformation.

.....

.....

.....

.....

.....

.....

.....

.....

.....

.....

(Total for Question 12 = 4 marks)



13 Archer fish spit water droplets at insects from the surface of the water.

- (a) The Archer fish spits a droplet of water with a velocity of 3.5 m s^{-1} at an angle of 70° to the horizontal, aiming for an insect on a branch above the surface of the water. The horizontal distance to the insect is 0.4 m .

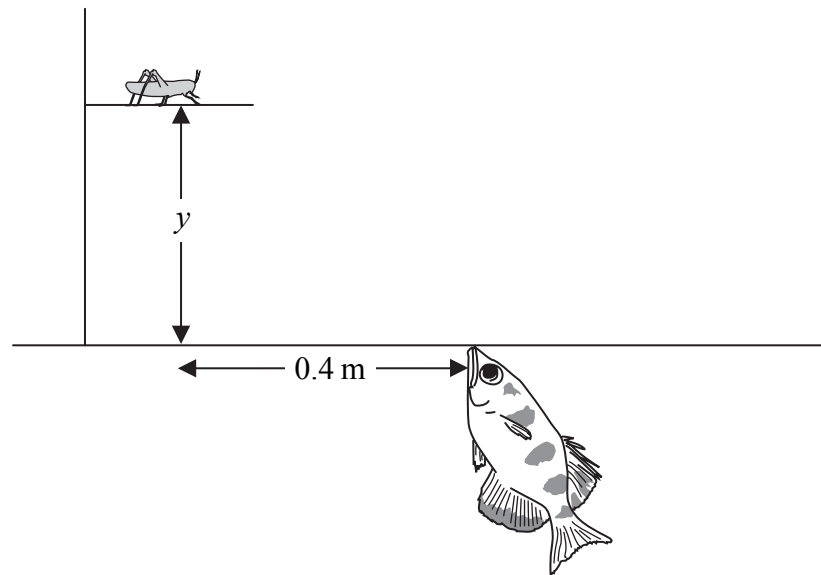

- (i) Show that the initial horizontal component of velocity for the droplet is about 1 m s^{-1} .

(2)

- (ii) Calculate the vertical distance, y , to the insect if the droplet hits the insect.

(5)

Distance =

- (b) Sketch the path of the water droplet on the diagram above.

(1)

(Total for Question 13 = 8 marks)



14 One method used to find the viscosity of a liquid is to measure the terminal velocity of a solid spherical object falling through it.

In such an experiment the following data are provided:

- weight of sphere = 4.8×10^{-3} N
- radius of sphere = 2.5×10^{-3} m
- volume of sphere = 6.5×10^{-8} m³
- density of liquid = 1300 kg m^{-3}

(a) Show that the upthrust is about 8×10^{-4} N.

(2)

.....

.....

.....

.....

(b) The terminal velocity is found to be $4.6 \times 10^{-2} \text{ m s}^{-1}$. Use this value to show that the viscosity of the liquid is about $2 \text{ kg m}^{-1} \text{ s}^{-1}$.

(3)

.....

.....

.....

.....

(c) The students carrying out this experiment wish to repeat it on another day using the same equipment. State another relevant variable that needs to be controlled to make this a fair test.

(1)

.....

(Total for Question 14 = 6 marks)

.....

.....



15 The photograph shows the top of an inspection cover for a drain.



(a) The cover is marked 'ductile'. It is made from ductile iron, which was invented in 1943. It replaced the previous form of cast iron, which was more brittle.

Explain the meaning of the following terms:

(2)

Ductile

Brittle

(b) The cover is also marked '35 kN'. This refers to the load it must be able to support.

Calculate the mass that would produce this load.

(2)

Mass =

(Total for Question 15 = 4 marks)



BLANK PAGE



16 There has been a proposal to build a train tunnel underneath the Atlantic Ocean from England to America. The suggestion is that in the future the trip of 5000 km could take as little as one hour.

Assume that half the time is spent accelerating uniformly and the other half is spent decelerating uniformly with the same magnitude as the acceleration.

(a) Show that the acceleration would be about 2 m s^{-2} . (2)

.....

.....

.....

.....

.....

(b) Calculate the maximum speed. (2)

.....

.....

Speed =

(c) Calculate the resultant force required to decelerate the train.
mass of train = $4.5 \times 10^5 \text{ kg}$ (2)

.....

.....

Force =

(Total for Question 16 = 6 marks)



17 A kite is held by a string and flies because of lift produced by the flow of air.

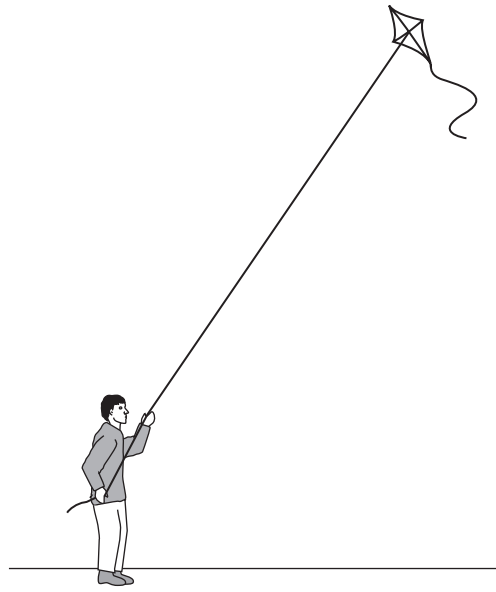

Figure 1

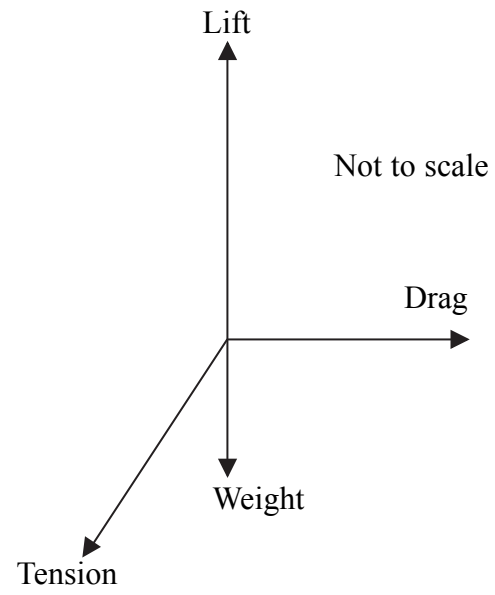

Figure 2

Figure 2 shows a free-body force diagram for the kite.

(a) Sketch a labelled vector diagram to show that the four forces are in equilibrium.

(1)



(b) The lift is 4.3 N, the drag is 6.0 N and the weight is 0.44 N.

Calculate the tension in the string. State its magnitude and direction from the horizontal.

(4)

.....

.....

.....

.....

.....

.....

.....

.....

Magnitude of tension =

Direction of tension from the horizontal =

(c) (i) The wind speed decreases so the girl flying this kite walks into the wind at a constant speed of 2.0 m s^{-1} to maintain the forces shown. Calculate the work done by the girl as she walks 25 m.

(2)

.....

.....

.....

.....

Work done =

(ii) Calculate the rate at which work is done by the girl.

(2)

.....

.....

.....

Rate at which work is done =

(Total for Question 17 = 9 marks)



***18** In a demonstration of energy transfer, a large pendulum is made by suspending a 7.0 kg bowling ball on a long piece of wire.

A student is invited to pull the ball back until it just touches her nose and then to release it and stand perfectly still while waiting for the ball to return.

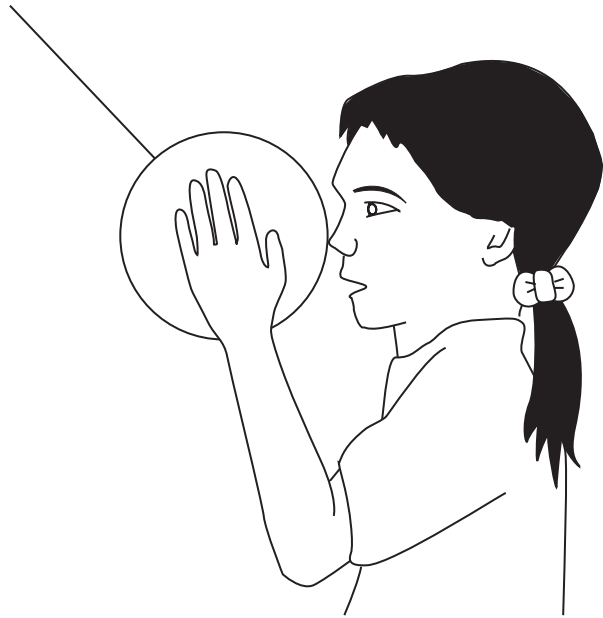

The following instructions are given:

Do not push the ball - just release it.
Do not move your face before the ball returns.

(a) Explain this demonstration and the need for these instructions.

(6)

.....

.....

.....

.....

.....

.....

.....

.....

.....

.....



(b) The bowling ball is raised through a vertical distance of 1.5 m.

(i) Calculate the gravitational potential energy gained by the ball.

(2)

.....
.....
.....

Gravitational potential energy =

(ii) Calculate the speed of the ball at the bottom of its swing.

(2)

.....
.....
.....

Speed =

(Total for Question 18 = 10 marks)



*19 The photograph shows a tin bought from a joke shop. When the lid is removed, a long spring, covered in fabric to resemble a snake, flies out of the tin.



The spring on its own is shown here.

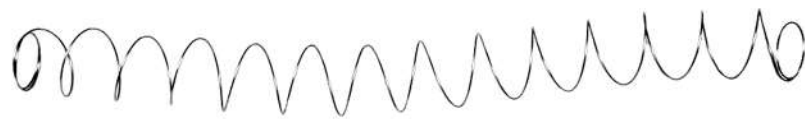

The graph shows length against force for the spring.

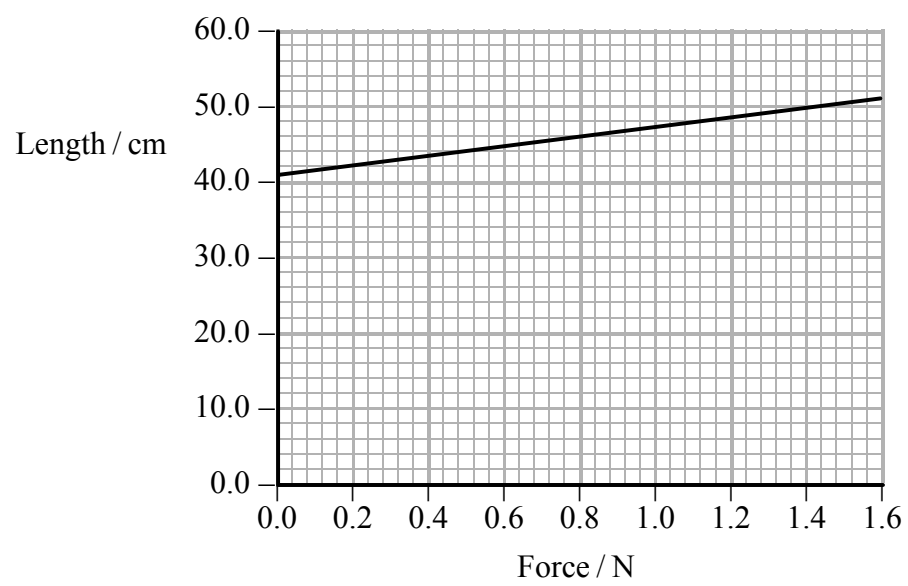

(a) Explain whether the spring obeys Hooke's law.

(2)

.....

.....

.....

(b) Show that the spring constant k of the spring is about 20 N m^{-1} .

(3)

.....

.....

.....

$k =$

(c) The original length of the spring is 41.0 cm and the length of the tin is 9.0 cm .

(i) Calculate the force that must be applied to the spring to get it into the tin.

(2)

.....

.....

.....

Force =

(ii) Calculate the energy stored in the spring when it is compressed to fit into the tin.

(2)

.....

.....

.....

Energy =



(d) In fact the bottom of the tin contains a device that makes a squeak when the spring is released, making the internal length of the tin less than 9.0 cm.

Explain the effect this has on the speed at which the spring leaves the tin.

(3)

.....

.....

.....

.....

.....

.....

.....

(Total for Question 19 = 12 marks)



20 The photograph shows a toy car driven by air from a deflating balloon.

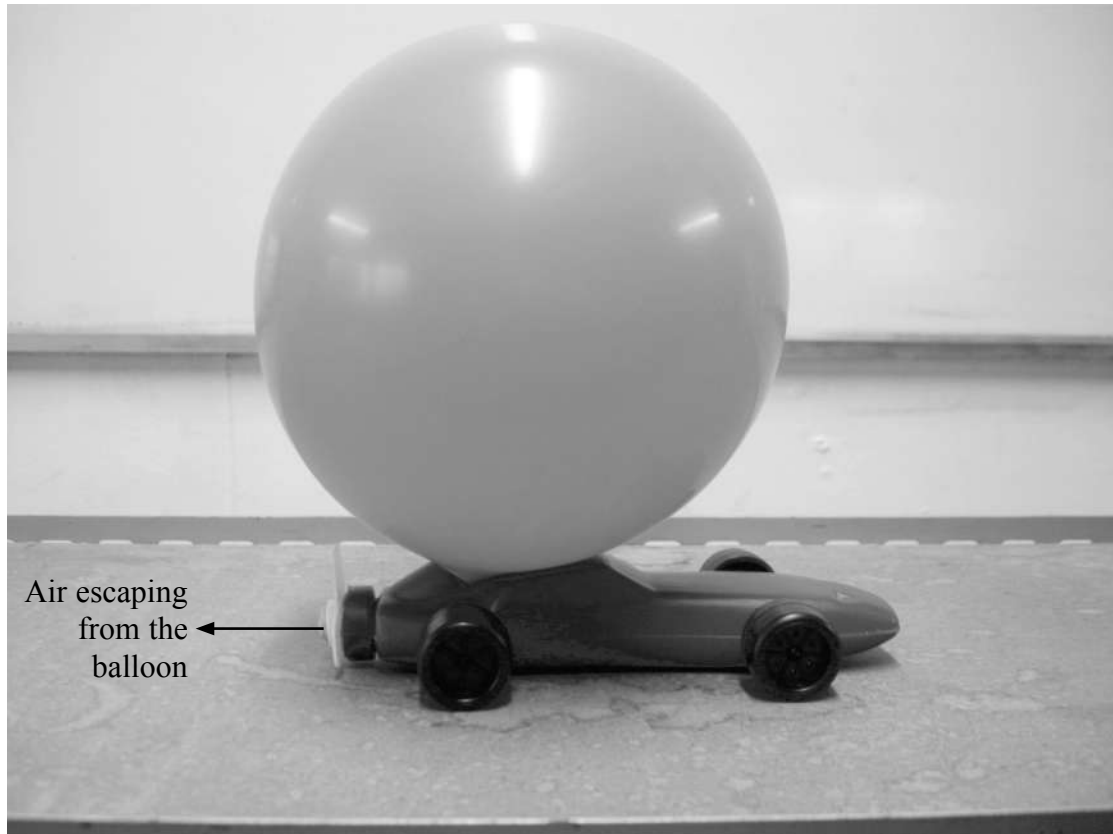

When the air in the inflated balloon is released, the car starts to move forwards.

(a) Use Newton's first and third laws of motion to explain why the air coming out of the balloon causes this.

(3)

.....

.....

.....

.....

.....

.....

.....

.....



(b) The following distance-time graph is obtained for the car.

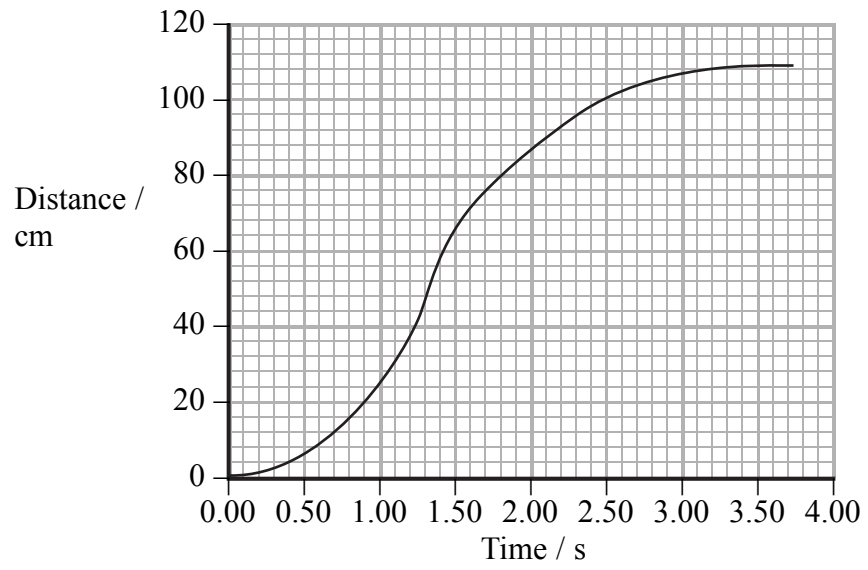

(i) Show that the maximum speed reached is between 100 and 150 cm s^{-1} .

(3)

.....

.....

.....

.....

(ii) Sketch the shape of the corresponding speed-time graph on the axes below.

(3)

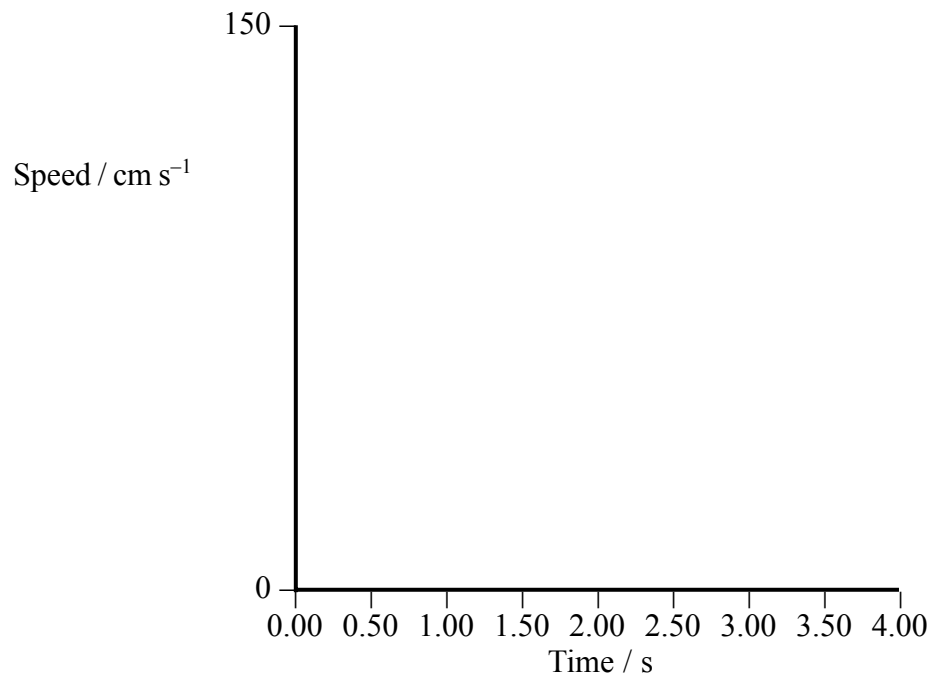

(Total for Question 20 = 9 marks)

TOTAL FOR SECTION B = 70 MARKS

TOTAL FOR PAPER = 80 MARKS



List of data, formulae and relationships

Acceleration of free fall	$g = 9.81 \text{ m s}^{-2}$	(close to Earth's surface)
Electron charge	$e = -1.60 \times 10^{-19} \text{ C}$	
Electron mass	$m_e = 9.11 \times 10^{-31} \text{ kg}$	
Electronvolt	$1 \text{ eV} = 1.60 \times 10^{-19} \text{ J}$	
Gravitational field strength	$g = 9.81 \text{ N kg}^{-1}$	(close to Earth's surface)
Planck constant	$h = 6.63 \times 10^{-34} \text{ J s}$	
Speed of light in a vacuum	$c = 3.00 \times 10^8 \text{ m s}^{-1}$	

Unit 1

Mechanics

Kinematic equations of motion	$v = u + at$ $s = ut + \frac{1}{2}at^2$ $v^2 = u^2 + 2as$
Forces	$\Sigma F = ma$ $g = F/m$ $W = mg$
Work and energy	$\Delta W = F\Delta s$ $E_k = \frac{1}{2}mv^2$ $\Delta E_{\text{grav}} = mg\Delta h$

Materials

Stokes' law	$F = 6\pi\eta rv$
Hooke's law	$F = k\Delta x$
Density	$\rho = m/V$
Pressure	$p = F/A$
Young's modulus	$E = \sigma/\epsilon$ where Stress $\sigma = F/A$ Strain $\epsilon = \Delta x/x$
Elastic strain energy	$E_{\text{el}} = \frac{1}{2}F\Delta x$



BLANK PAGE

